



World Leader in Lift Productivity

ML40

Scissor Lifts



OPERATION  
&  
MAINTENANCE  
MANUAL



## EC Declaration of Conformity

according to EC directive 2006/42/EC on machinery (Annex II A)

Name and address of the manufacturer

**Adriatic Painting Srl Via degli Elettricisti 16 – 64025 Pineto (TE) Italia**

*This declaration relates exclusively to the machinery in the state in which it was placed on the market, and excludes components which are added and/or operations carried out subsequently by the final user. The declaration is no more valid, if the product is modified without agreement.*

**Herewith we declare, that the machinery described below**

**product denomination: SCISSOR LIFT**

**MODEL: ML 40N / ML 40LT / ML 50N / ML 50LT**

serial number: .....

Year of manufacture: **2011**

*is complying with all essential requirements of the Machinery Directive 2006/42/EC. In addition the partly completed machinery is in conformity with the EC Directives 2004/108/EC relating to electromagnetic compatibility and 2006/95/EC relating to electrical equipment (Protection objectives have been met in accordance with Annex I No. 1.5.1 of the Machinery Directive 2006/42/EC).*

### Harmonized Standards used

EN 1493:2010	Vehicle lifts
EN ISO 12100-1 : 2003	Safety of Machinery- Basic concepts
EN ISO 12100-2 : 2003	Safety of Machinery- Basic concepts
EN 60204-1:2006+32/2008	Electrical equipment of machines
EN 349:1993+A1:2008	Safety of machinery - Minimum gaps
EN ISO 13850:2008	Safety of machinery – Emergency stop
EN ISO 14121-1:2007	Safety of machinery - Risk assessment

### The person authorized to compile the relevant technical documentation:

Ing. Giovanni Mastrangelo; Via degli elettricisti 16 – 64025 Pineto (TE)

Place : Pineto(TE)

Date :01.06.2011

**ADRIATIC PAINTING S.R.L.**  
Via degli Elettricisti - F.no Scarna  
64025 PINETO (TE)  
Tel. 085 9461251  
E. Part. Reg. Imp. 01602310672  
Stefano Pennazza  
Managing Director

### Contents

<b>1</b>	<b>Identification and warranty</b>	<b>4</b>
1.1	Manufacturer	4
1.2	Product description	4
1.3	Operating manual	4
1.4	Warranty	5
1.5	Transport damage	5
1.6	Ordering of spare parts	5
<b>2</b>	<b>Product description</b>	<b>6</b>
2.1	Mechanical design	6
2.2	Functional description	6
2.3	Technical data	7
<b>3</b>	<b>Basic safety instructions</b>	<b>8</b>
3.1	General safety information	8
3.2	Proper use	9
3.3	Warning and safety notices used	10
3.3.1	Structure of the warning notices	10
3.3.2	Explanation of the warning levels	10
3.3.3	Explanation of the icons	11
3.4	Technical condition of the equipment	12
3.5	Obligations of the operating company	12
3.6	General work safety	12
3.7	Safety instructions in regard to specific energy systems	13
3.7.1	Electrical system	13
3.7.2	Hydraulic system	13
3.7.3	Mechanical system	13
3.7.4	Surface temperature	14
3.8	Safety devices on the machine	15
3.8.1	Deadman control	15
3.8.2	Independent hydraulic circuits	15
3.8.3	Euro Stop	15
3.8.4	Main switch	15
3.8.5	Pressure limiting valve	15
3.8.6	Line breakage protection in the cylinder connection	15
3.9	Safety and warning notices	16
3.10	Safety instructions for personnel	17
3.10.1	Personnel and qualifications	17
3.11	Safety instructions for auxiliary materials and consumables	17
3.11.1	Hydraulic oils, lubricants and cleansers	17
<b>4</b>	<b>Transport</b>	<b>18</b>
4.1	Basic safety instructions	18
4.2	Transport to the installation location	18
<b>5</b>	<b>Installation</b>	<b>19</b>
5.1	Basic safety instructions	19
5.2	Location requirements for setup	19

5.3	Assembly at the installation site . . . . .	20
5.3.1	Setting up . . . . .	20
5.4	Electrical installation . . . . .	21
<b>6</b>	<b>Starting up . . . . .</b>	<b>22</b>
6.1	Basic safety instructions . . . . .	22
6.2	Initial commissioning . . . . .	22
6.3	Settings . . . . .	23
6.3.1	Top position sensor . . . . .	23
6.3.2	Euro Stop sensor . . . . .	23
6.3.3	Intermediate stop sensor . . . . .	23
<b>7</b>	<b>Operation . . . . .</b>	<b>24</b>
7.1	Basic safety instructions . . . . .	24
7.2	Description of the controls . . . . .	25
7.3	Lifting and lowering the vehicle . . . . .	26
<b>8</b>	<b>Shutting down . . . . .</b>	<b>28</b>
8.1	Temporary shutdown . . . . .	28
8.2	Permanent shutdown . . . . .	28
<b>9</b>	<b>Maintenance and inspections . . . . .</b>	<b>29</b>
9.1	Basic safety instructions . . . . .	29
9.2	Maintenance schedule . . . . .	30
9.3	Cleaning the machine . . . . .	30
9.4	Inspecting the sliding bearings . . . . .	31
9.5	Servicing the hydraulic system . . . . .	31
9.5.1	Checking the hydraulic oil level . . . . .	32
9.5.2	Changing the hydraulic oil . . . . .	32
9.5.3	Bleeding the hydraulic system . . . . .	32
9.5.4	Aerating the main lifting unit . . . . .	32
9.5.5	Aerating the hydraulic system of the wheel-free lift (LT/LTAT version only) <sup>35</sup>	
9.5.6	Checking the hydraulic hoses . . . . .	36
9.6	Inspections . . . . .	36
9.6.1	Regular inspections . . . . .	36
9.6.2	Additional inspections . . . . .	37
9.6.3	Inspection list . . . . .	38
<b>10</b>	<b>Help for malfunctions . . . . .</b>	<b>39</b>
10.1	Machine does not lift . . . . .	39
10.2	Machine does not reach the full lift height . . . . .	39
10.3	Electric motor does not run . . . . .	39
10.4	Machine does not lower (completely down) . . . . .	40
10.5	Oil leak . . . . .	40
10.6	Machine deflects heavily when load is changed . . . . .	40
<b>11</b>	<b>Appendix . . . . .</b>	<b>41</b>

# 1 Identification and warranty

## 1.1 Manufacturer

Manufacturer: BlitzRotary GmbH  
Street: Hüfingener Straße 55  
City/country: 78199 Bräunlingen, Germany

Phone: +49 (0) 771 - 92 33-0  
Fax: +49 (0) 771 - 92 33-99

E-mail: europe@rotary.com  
Internet: www.rotarylif.com

## 1.2 Product description

Machine type: ML 40  
Machine no.:  
Year of construction: 2008

## 1.3 Operating manual

We reserve the right to make modifications as regards content. BlitzRotary GmbH is not liable for any errors in this documentation. Liability for secondary damages arising in connection with the delivery or use of this documentation is excluded to the extent that legal regulations permit.

### Proprietary note

© 2008 BlitzRotary GmbH, Hüfingener Straße 55, 78199 Bräunlingen, Germany. All rights reserved. Photocopying, reproducing, translating or recording onto data carrier devices, either in whole or in part, is only permitted with the written approval of BlitzRotary GmbH.

### 1.4 Warranty

Every machine is covered under a 12-month warranty for material defects and faulty assembly, providing this assembly was performed by us. The warranty extends to all parts which are sent to us for inspection free of charge within twelve months after delivery. We will examine the parts in order to determine whether the damage has arisen under normal conditions of use. The warranty is void if the machine is overloaded, improperly handled, or spare parts have been improperly installed and thereby cause damage.

### 1.5 Transport damage

All deliveries are to be insured by the customer. We will not honor any claims related to transport responsibility. Our responsibility only extends to the transfer of the machine in new factory condition to the carrier. Should you find any damage on the machine, do not use it. Note the type of damage immediately on the bill of lading. Contact the carrier in order to review the claim.

### 1.6 Ordering of spare parts

**Please specify the following data when ordering:**

- Machine type
- Machine no.
- Year of construction
- Part name

## 2 Product description

### 2.1 Mechanical design

**The machine consists of the following main components:**

- Two lifting units, each of which are made up of:
  - underframe
  - scissor assembly
  - running rails
- Control column with integrated hydraulic unit

### 2.2 Functional description

By pressing the «Lift» control on the control device, the electric motor of the hydraulic unit is switched on. The oil pump of the hydraulic unit pumps hydraulic oil into the hydraulic cylinders. The hydraulic cylinders extend and the scissor assembly is pressed apart and lifts the running rails.

By pressing the «Lower» control on the control device, the electronically releasable check valve is opened and hydraulic oil flows back into the hydraulic tank. The platform lowers.



## 2.3 Technical data

### Mechanical data

Load capacity:	4,000 kg
Load capacity, wheel-free lift:	3,500 kg
Overall height:	180 mm (N, LT) 250 mm (NAT, LTAT)
Usable stroke:	1,670 mm
Platform length:	4,200 mm
Platform width:	725 mm
Platform surface:	plain sheet
Weight:	3,500 kg

### Electrical system

Connection:	3Ph400V/PE/50Hz/16A
Power:	3.6 kW (N, NAT) 4.0 kW (LT, LTAT)
Current consumption:	7,3 A
Protection type:	IP54
Operating voltage:	400 V
Control voltage:	24 V

### Hydraulics

Oil fill quantity:	10 l
--------------------	------

### Sound emission

Sound pressure level:	<70 dB (A)
-----------------------	------------

## 3 Basic safety instructions

### 3.1 General safety information

The machine was designed and manufactured under consideration of a hazard analysis and on the basis of the relevant harmonised norms as well as additional technical specifications. It corresponds to the latest technological standards valid at the time of manufacture and the relevant safety regulations.

The machine is equipped with protective devices and was subject to a safety and acceptance test. However, incorrect operation or improper use can pose a threat to the lives and health of personnel. Damage to the machine itself, other equipment or to the environment cannot be ruled out.

All work on the machine may only be performed by qualified and authorised persons who have read the relevant sections in this operating manual and agree to observe them.

#### **For transport**

- *Chap. 2 "Product description", page 6*
- *Chap. 3 "Basic safety instructions", page 8*
- *Chap. 4 "Transport", page 18*

#### **For setup**

- *Chap. 2 "Product description", page 6*
- *Chap. 3 "Basic safety instructions", page 8*
- *Chap. 4 "Transport", page 18*
- *Chap. 5 "Installation", page 19*

#### **For startup**

- *Chap. 2 "Product description", page 6*
- *Chap. 3 "Basic safety instructions", page 8*
- *Chap. 6 "Starting up", page 22*
- *Chap. 7 "Operation", page 24*

#### **For operation**

- *Chap. 2 "Product description", page 6*
- *Chap. 3 "Basic safety instructions", page 8*
- *Chap. 7 "Operation", page 24*

#### **For shutting down**

- *Chap. 2 "Product description", page 6*
- *Chap. 3 "Basic safety instructions", page 8*
- *Chap. 7 "Operation", page 24*
- *Chap. 8 "Shutting down", page 28*

### For maintenance and inspections

- *Chap. 2 "Product description", page 6*
- *Chap. 3 "Basic safety instructions", page 8*
- *Chap. 7 "Operation", page 24*
- *Chap. 9 "Maintenance and inspections", page 29*

## 3.2 Proper use

The machine lifts vehicles continuously to any ergonomically favourable height. The permissible load capacity may not be exceeded (see load capacity plate, type plate or *Chap. 2.3 "Technical data", page 7*).

The machine may only be used as intended! Severe injuries or equipment damage can result from improper use! This is not the responsibility of the manufacturer of the machine, but of the operating company!

The machine is designed for the performance of work underneath the load-bearing equipment and the vehicle. It is not approved for supporting or transporting persons.

### The following is especially prohibited:

- Transport of persons.
- Standing on the platform.
- Operating in areas at risk of explosion.
- Operating in areas requiring a protection type for the electrical equipment higher than IP 54.

### 3.3 Warning and safety notices used

Warning and safety notices contain information designed to point out the unavoidable residual risks involved in handling the machine.

The hazards apply to the following:

- Persons
- Machine
- Equipment
- Environment

#### 3.3.1 Structure of the warning notices

The warning notices of this operating manual have an identical basic structure.

Icon

Danger sign

Signal word



**DANGER**

**Type and source of danger**

Possible consequences of non-observance

- Avoidance: measures / prohibitions
- 

#### 3.3.2 Explanation of the warning levels

Warning level	Consequences of non-observance
<b>DANGER</b>	Immediate danger of severe injuries or death
<b>WARNING</b>	Severe injuries or death are possible
<b>CAUTION</b>	Minor injuries are possible
<b>NOTE</b>	Equipment damage

### 3.3.3 Explanation of the icons

Warning and safety notices are supplemented by visual icons if possible. An icon cannot replace the text! The text must therefore always be read in its entirety!

The following icons are examples.

Icon	Meaning
	Warning of a danger to persons
	Warning of electrical shock
	Warning of points where crushing can occur
	Warning of health hazards posed by toxic substances
	Warning of environmental hazards
	Warning of equipment damage
	The following work may only be performed by qualified and authorised persons.
	General information for better understanding and optimum handling of the machine

### 3.4 Technical condition of the equipment

Safe operation places particular demands on the technical condition of the machine.

- Rebuilding, manipulation or making modifications to the machine is not permitted. This also applies to the use of replacement parts that are not supplied by us.
- Care and maintenance should be performed at the specified intervals.
- Regular inspections are to be carried out.
- Complete and proper functioning of the safety devices during operation must be ensured at all times.
- Connection and setting values must correspond to the specifications.
- Load specifications must be observed.

### 3.5 Obligations of the operating company

The highest possible level of safety can only be achieved in operating practice if all measures required for it have been taken. It is the responsibility of the operating company to plan these measures and monitor their implementation.

**The operating company must ensure the following in particular:**

- The machine is only used as intended (*Chap. 3.2 "Proper use", page 9*).
- The machine is only operated in technically flawless and functional condition.
- The safety devices are regularly checked for proper functioning. The safety devices may not be disabled or have their functions restricted.
- The maintenance and inspection intervals specified in this operating manual are observed (*Chap. 9 "Maintenance and inspections", page 29*).
- All safety and warning notices attached to the machine are present and in legible condition. Notices on the machine that have become damaged or illegible are to be replaced immediately.
- Only qualified and authorised personnel may operate, service and inspect the machine.
- These persons must be regularly instructed in all applicable aspects of work safety and environmental protection, as well as be familiar with and follow the operating manual and the safety instructions contained within it.
- The required personal protective equipment for operating, maintenance and inspection personnel must be made available and used.
- The operating manual should be complete and in legible condition and readily accessible where the machine is in use.
- Further risks must be determined in a risk assessment and the respective danger zone must be identified under consideration of the special work conditions where the machine is in use.
- All additional instructions and safety notices must be summarised in a company directive based on the risk assessment of the workstations on the machine.

### 3.6 General work safety

When the machine is used, dangers due to incorrect operation or misuse may pose a hazard to persons, equipment or the environment.

- The machine may only be operated, serviced and inspected by qualified and authorised personnel who have read the operating manual and perform their work accordingly.
- Only operate the machine in technically flawless and functional condition.
- If damage is detected, immediately switch off the machine, attach a sign informing others that switching back on is prohibited and then inform your supervisor.
- Maintain the cleanliness of the machine and its surroundings.
- Wear personal protective equipment.

### 3.7 Safety instructions in regard to specific energy systems

#### 3.7.1 Electrical system

The machine is equipped with an electrical system that operates with high voltage.

- Prior to beginning work, inspect the electrical system for visible signs of damage. Immediately replace damaged components.
- Before performing maintenance work, switch off the current to the electrical system and prevent it from being accidentally switched back on.
- Always keep the control boxes closed.
- Lay lines so that they do not pose a stumbling hazard and so that damage due to falling objects, pinching or abrasion is avoided.
- Do not lay lines around moving components and ensure that the lines cannot catch on any moving components.
- Protect the electrical system from penetration by water or other liquids.
- Regularly inspect lines, especially after maintenance work, for secure fit.

#### 3.7.2 Hydraulic system

Hydraulic oil, lubricants and other substances, such as solvents or cleansers, can lead to irritation of the skin, eyes or respiratory tract. These also pose a hazard to the environment.

- Observe the safety instructions of the manufacturer.
- Use personal protective equipment.
- Use a breathing protection mask if necessary.
- Avoid contact with the skin. Should contact with skin arise, wash thoroughly.
- In the event of contact with eyes, rinse and consult a physician.
- Ensure that no substances contaminate the ground or enter the sewer system.
- Dispose of hydraulic oil, lubricants and cleansers in accordance with environmental regulations.

#### 3.7.3 Mechanical system

When using and working on the machine, mechanical hazards are present. These hazards are posed in the area of the mechanics underneath the platform.

## Basic safety instructions

---

- Do not reach into or enter the danger zone.
- Avoid standing in the danger zone.
- Remove any foreign objects from the danger zone.



Fig. 3-1 Mechanical danger zones

### 3.7.4 Surface temperature

Due to friction, certain components (particularly of the hydraulic system) can have high surface temperatures.

- Before inspections and maintenance work, allow the machine to cool down.
- Use personal protective equipment.
- Check the oil level (*Chap. 9.5.1 "Checking the hydraulic oil level", page 32*). If the oil level is too low, the temperature of the hydraulic system will be additionally increased. This can lead to higher wear.



## **3.8 Safety devices on the machine**

### **3.8.1 Deadman control**

The deadman control of the machine ensures that the function is only carried out as long as the operator holds the respective control pressed on the control device.

### **3.8.2 Independent hydraulic circuits**

Two hydraulic circuits independent of one another prevent the unintended lowering of the platform. In the event of a break in a hydraulic line in one of the hydraulic circuits, the other hydraulic circuit holds the platform.

### **3.8.3 Euro Stop**

When lowering the platform, the Euro Stop feature stops the lowering process in order to prevent crushing and other hazards. The sensor for the Euro Stop must be set at the time of initial commissioning (*Chap. 6.3.2 "Euro Stop sensor", page 23*).

### **3.8.4 Main switch**

The main switch turns the current supply to the machine on and off.

The main switch is also an emergency off switch. In the event of an emergency, set the switch to the "0" position.

### **3.8.5 Pressure limiting valve**

The pressure limiting valve prevents overloading of the hydraulic system. It is factory preset and may not be adjusted by the operating company. When overloaded, the platform can no longer be raised.

### **3.8.6 Line breakage protection in the cylinder connection**

The line-break safety device in the cylinder connection interrupts the flow if a break occurs in the hydraulic lines.

**3.9 Safety and warning notices**

The machine is labelled with various notices. The notices should always be present and in legible condition.

 <p><b>4000</b> CAPACITY PORTATA <b>KG</b> CAPACITE' TRAGFÄHIGKEIT</p> <p><b>3500</b> CAPACITY PORTATA <b>KG</b> CAPACITE' TRAGFÄHIGKEIT</p>	<p><b>Note!</b> Maximum load capacity.</p>
---	--

## 3.10 Safety instructions for personnel

### 3.10.1 Personnel and qualifications



---

All persons working with the machine must read the operating manual prior to beginning the work and confirm with their signature that they have understood what they have read and agree to observe it.

---

- Only persons of at least 18 years of age who have been instructed in the machine's operation, and have demonstrated their ability in this regard to the employer, may be delegated with operation of the machine.
- The assignment to the task of operating the machine must be given in writing.
- The respective authorisations of the person must be defined.
- Trainees must receive instruction. The instruction may only be performed by experienced persons authorised to do so and using this operating manual as a basis.
- Instructed persons confirm in writing the scope of instruction received and their successful completion of it.

## 3.11 Safety instructions for auxiliary materials and consumables

### 3.11.1 Hydraulic oils, lubricants and cleansers

Hydraulic oil, lubricants and other substances, such as solvents or cleansers, can lead to irritation of the skin, eyes or respiratory tract. These also pose a hazard to the environment.

- Observe the safety instructions of the manufacturer.
- Use personal protective equipment.
- Use a breathing protection mask if necessary.
- Avoid contact with the skin. Should contact with skin arise, wash thoroughly.
- In the event of contact with eyes, rinse and consult a physician.
- Ensure that no substances contaminate the ground or enter the sewer system.
- Dispose of hydraulic oil, lubricants and cleansers in accordance with environmental regulations.

## 4 Transport

### 4.1 Basic safety instructions



#### WARNING

##### Suspended or falling loads

Severe injuries or death

- The permitted loads of the load hoisting equipment must at least correspond to the dead weight of the machine (see load capacity plate, type plate or *Chap. 2.3 "Technical data", page 7*).
  - Wear a protective helmet.
  - Do not step under suspended loads.
- 

### 4.2 Transport to the installation location

The transport can be performed with a forklift or a crane. When transporting with a crane, ensure that the machine does not sway too heavily.



*Fig. 4-1 Transport*

## 5 Installation

### 5.1 Basic safety instructions



#### WARNING

##### Scissors and castors

Crushing or amputation of limbs

- Do not reach or step into the danger zone (*Fig. 3-1, page 14*).
- 

##### **Before setting up the machine**

- ▶ Inspect the machine for visible signs of damage.
- ▶ Remove materials and objects from the work area if they are not required.
- ▶ Observe the location requirements for setup (*Chap. 5.2 "Location requirements for setup", page 19*).
- ▶ Observe the proper procedure for transport (*Chap. 4 "Transport", page 18*).

*The preparations are completed.*

### 5.2 Location requirements for setup

- Avoid points of crushing and shearing between the machine and its surroundings.
- The machine may not be operated in areas at risk of explosion, nor in places where the electrical equipment requires a protection type higher than IP 54.
- The ambient temperature must lie between -10 °C and +40 °C.
- The installation site must provide a sufficiently load-bearing and level foundation.
- The flooring at the installation site must be of permissible floor loading strength, calculated as follows: (weight of machine + load capacity) + 50 %.
- When selecting the installation site, ensure that any noise emitted from the machine (due to design) is not further amplified.
- Place the controls in a location ensuring the operator has a clear view of the load and the machine, particularly including the danger zone (*Fig. 3-1, page 14*).  
Ensure that the operator has avenues of escape if a danger arises.
- An electrical connection conforming to Chap. 2.3 "Technical data", page 7 is to be made available for the operation of the machine.
- Observe any local regulations and rules for buildings.



---

The floor must have a minimum compression strength of 20 N/mm<sup>2</sup>.

The retaining bores must have a distance of at least 110 mm from the edge of the concrete.

---

## 5.3 Assembly at the installation site

### 5.3.1 Setting up



#### NOTICE

##### Incorrect setup or assembly

Incorrect setup or assembly of the machine can lead to equipment damage and increased wear.

- Follow the instructions for setup and assembly.
- 

##### *Mechanical assembly work*

- ▶ Measure the underframe of the machine and transfer the measurements to the installation site.
- ▶ Measure the height differences at the designated corners.
- ▶ Compensate for the differences at the corners with base plates laid underneath.
- ▶ Erect the machine at the installation site.
- ▶ Check the machine with a water level and employ additional base plates if necessary.
- ▶ Dowel the machine as follows (Fig. 5-2, page 21):
  - ▶ Drill holes (borehole diameter: 16 mm; borehole depth: min. 110 mm).
  - ▶ Clean boreholes.
  - ▶ Insert dowels.
  - ▶ Insert washers and nuts.
  - ▶ Tighten nuts (torque 100 Nm).
- ▶ Lay the control and supply lines.

*The mechanical installation work is complete.*

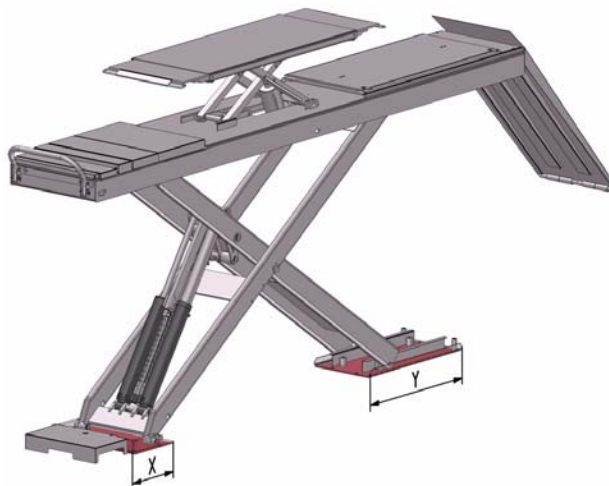

Fig. 5-1 Fixed bearing area (x) and castor area (y) of the underframe

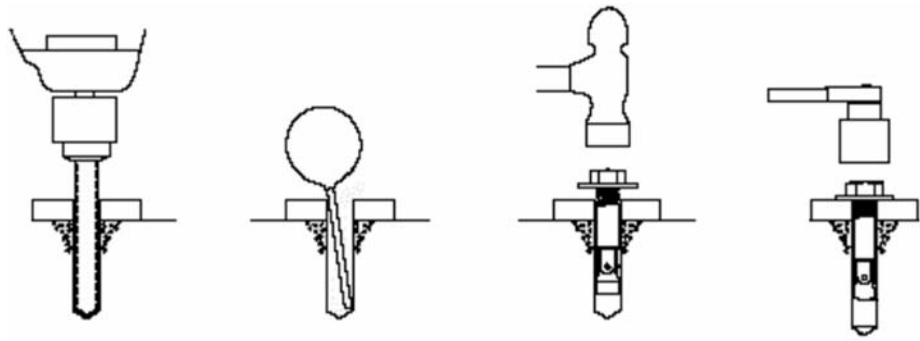

Fig. 5-2 Fastening to the floor

### **Fitting the hydraulic hoses**

- ▶ The control column can be set up to the right or the left of the scissor lift platform. The connection diagrams for the hydraulic hoses are in the appendix of this operating manual.
- ▶ Place the control column in position.
- ▶ Lay and fit the hydraulic hoses according to the connection diagrams.

*The fitting of the hydraulic hoses is completed.*

## 5.4 Electrical installation



### **WARNING**

#### **High electrical voltage**

Severe injury or death from electrical shock

- Only trained electricians may work on the electrical system.



### **CAUTION**

#### **Laying of cables**

Injury

- Avoid creating stumbling hazards with cables.
- Do not lay control and supply lines around mechanical components.



Secure the machine with a lockable main switch to prevent unauthorised operation or so that the machine can be safely disconnected from the mains electricity supply.

## 6 Starting up

### 6.1 Basic safety instructions



---

Prior to the initial commissioning, a safety inspection must be performed by a qualified and authorised person. This person must confirm and document the technically flawless functioning of the machine.

---



---

In Germany, inspection according to GUV-G 945 must be carried out. For this, use the inspection log book in the appendix of this operating manual.

---

**The following is to be checked:**

- correct installation
- proper functioning of safety devices
- operational readiness

### 6.2 Initial commissioning

***Prior to initial commissioning***

- ▶ Inspect the machine for visible signs of damage.  
If damage is detected:
  - ▶ Do not switch on the machine.
  - ▶ Attach or erect a notice sign prohibiting switching on the machine.
  - ▶ Notify your supervisor of the detected damage.
  - ▶ Only use the machine if all damage has been repaired.
- ▶ Remove any foreign objects from the danger zone (*Fig. 3-1, page 14*).
- ▶ Remove materials and objects from the work area if they are not required.
- ▶ Check and ensure that all safety devices are functioning flawlessly.

*The preparations are completed.*

**Before starting the machine, check and ensure the following:**

- Only authorised persons are in the work area of the machine.
- No one will be endangered by the starting up of the machine.
- Measures have been taken to prevent unintended changes in the position of the load.
- A clear view is available of the load, the machine and particularly the danger zone (*Fig. 3-1, page 14*).
- Avenues of escape are available in the event of danger.

***Starting***

- ▶ Turn the main switch to "1"
- ▶ Press the «Lift» control

***Check the following after the first startup:***

- ▶ All hydraulic hoses for airtightness.



## 6.3 Settings

### 6.3.1 Top position sensor

The "top position" sensor is located on the inner side of the master lifting unit. It should be adjusted so that the lift platform stops *before* the hydraulic cylinders reach the upper end position.

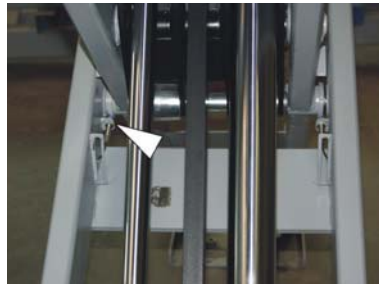

Fig. 6-1 Sensor for top position

### 6.3.2 Euro Stop sensor

The sensors for the Euro Stop are located on the outer sides of both lifting units. They are to be adjusted so that the lift platform stops if the distance between the upper edge of the underframe and the lower edge of the upper frame (h) amounts to at least 120 mm to max. 250 mm.

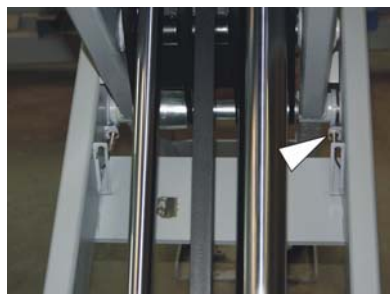

Fig. 6-2 Euro Stop sensor

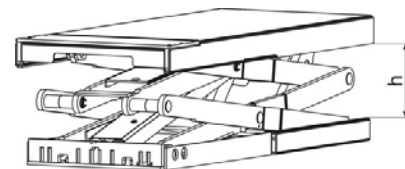

Fig. 6-3 Euro Stop distance

### 6.3.3 Intermediate stop sensor

The sensor for the intermediate stop function is located on the inner side of the slave lifting unit.

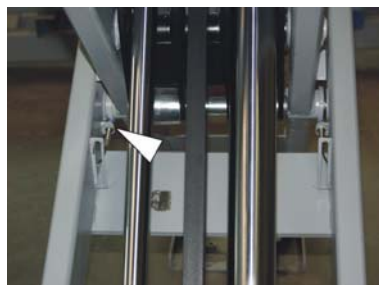

Fig. 6-4 Intermediate stop sensor

## 7 Operation

### 7.1 Basic safety instructions



#### WARNING

##### Scissors and castors

Crushing or amputation of limbs

- Do not reach or step into the danger zone (*Fig. 3-1, page 14*).
- 



#### WARNING

##### Improper placement of the load

Death or severe injuries from falling loads

- Observe the permissible load capacity of the machine (see load capacity plate, type plate or *Chap. 2.3 "Technical data", page 7*).
  - Only place loads of the permissible type on the machine.
  - The load may not protrude beyond the platform.
  - Prevent unintended changes in the position of the load.
- 



#### NOTICE

##### Incorrect operation

Severe damage to the machine

- Avoid repeated, sudden jolts when lifting and lowering the platform.
- 

##### ***Before beginning each work shift***

- ▶ Inspect the machine for visible signs of damage.  
If damage is detected:
  - ▶ Do not switch on the machine.
  - ▶ Attach or erect a notice sign prohibiting switching on the machine.
  - ▶ Notify your supervisor of the detected damage.
  - ▶ Only use the machine if all damage has been repaired.
- ▶ Remove any foreign objects from the danger zone (*Fig. 3-1, page 14*).
- ▶ Remove materials and objects from the work area if they are not required.
- ▶ Check and ensure that all safety devices are functioning flawlessly.

*The preparations are completed.*

**Before operating the machine each time, check and ensure the following:**

- Only authorised persons are in the work area of the machine.
- No one will be endangered by the starting up of the machine.
- Measures have been taken to prevent unintended changes in the position of the load.
- A clear view is available of the load, the machine and particularly the danger zone (*Fig. 3-1, page 14*).
- Avenues of escape are available in the event of danger.

### 7.2 Description of the controls

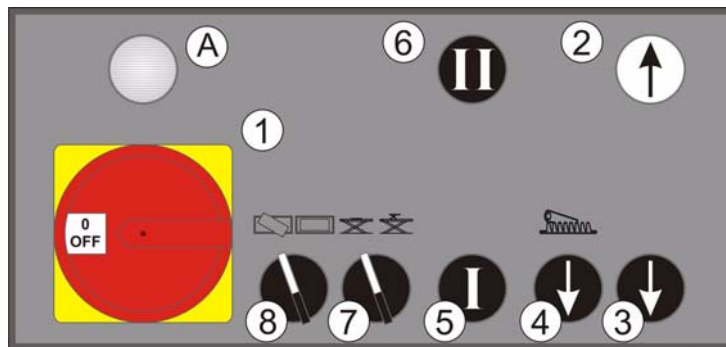

*Fig. 7-1 Control device*

- 1) Control: «Main switch»  
Setting the switch to "1" switches on the power supply - control lamp (A) lights up.  
Setting the switch to "0" switches off the power supply - control lamp (A) goes dark.  
The «main switch» can be locked with a padlock. This secures the machine against unintentional operation.
- 2) Control: «Lift»  
By pressing the «Lift» control, the platform raises.  
The movement stops as soon as the control is no longer held pressed (dead-man control).
- 3) Control: «Lower»  
By pressing the «Lower» control, the platform lowers.  
The movement stops as soon as the control is no longer held pressed (dead-man control).  
When the Euro Stop is reached, the lowering motion stops in order to prevent crushing and other hazards. If the lowering motion is to be resumed, press

the «Lower» control again. The platform continues to lower at a slower speed and a warning signal sounds.

- 4) «Lower to latched position» control  
By pressing the «Lower to latched position», control, the platform lowers into the latched position.  
After every raising or lowering, the lift platform should be moved into the latched position.
- 5) «Preset position 1» control  
By briefly activating this control and then pressing the «Lift» or «Lower» control, the platform moves to a previously set position.
- 6) «Preset position 2» control  
By briefly activating this control and then pressing the «Lift» or «Lower» control, the platform moves to a previously set position.
- 7) «Main lifting unit / Wheel-free lift» control  
By pressing this control, the operation switches between the main lifting unit and the wheel-free lift.
- 8) «Moving platform lock» control  
Switching the control locks/unlocks the moving platform.

### 7.3 Lifting and lowering the vehicle

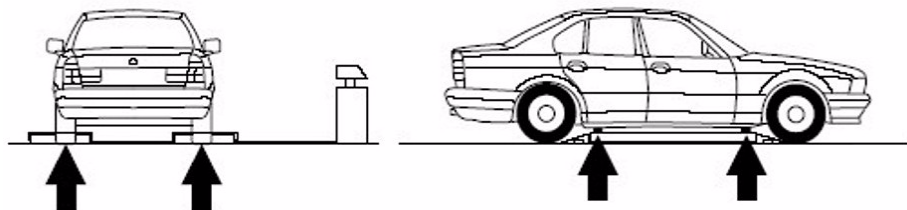

Fig. 7-2 Vehicle on the platform



#### NOTICE

##### **Incorrect driving on the platform.**

Risk of damaging the scissor lift platform or the vehicle.

- The platform must be completely lowered.
- Only drive onto the platform slowly and with caution.
- Avoid sudden braking.
- For lifting, the vehicle must be centred on the platform.

---

##### ***Moving the platform and lifting the vehicle***

- ▶ Lower the platform completely.
- ▶ Drive the vehicle slowly and cautiously to the middle of the platform.
- ▶ Place the supplied rubber blocks under the points provided for this purpose by the vehicle manufacturer.
- ▶ Carefully press the «Lift» control and raise the platform slightly.
- ▶ Check the position of the rubber blocks again and correct if necessary.
- ▶ Press the «Lift» control and continue raising the platform.

*The vehicle can now be raised to the desired height.*

### ***Lowering the platform and bringing off the vehicle***

- ▶ Press the «Lower» control and lower the platform. When the Euro Stop sensor is reached, the lowering motion stops.
- ▶ Press the «Lower» control again. The platform continues lowering more slowly. A warning tone sounds.
- ▶ Lower the platform completely.
- ▶ Remove the rubber blocks.

*The vehicle can now be driven slowly and carefully off the platform.*

## 8 Shutting down



### WARNING

#### High electrical voltage

Severe injury or death from electrical shock

- Only trained electricians may work on the electrical system.
- 

### 8.1 Temporary shutdown

#### ***Shutting down at the end of a work shift***

- ▶ Lower the platform completely.
- ▶ Turn the main switch to "0".

#### ***Shutting down for storage***

- ▶ Lower the platform completely.
- ▶ Disconnect the machine from the mains electricity supply.
- ▶ Clean the machine (*Chap. 9.3 "Cleaning the machine", page 30*).
- ▶ Transport it to the storage site (*Chap. 4 "Transport", page 18*).
- ▶ Carry out corrosion protection measures appropriate for the storage conditions and length of time to be stored.
- ▶ When putting the machine back into operation, perform commissioning and an additional inspection (*Chap. 6 "Starting up", page 22, Chap. 9.6.2 "Additional inspections", page 37*).

### 8.2 Permanent shutdown



---

The handling and disposal of mineral-based oils is subject to legal regulations. Bring used oil to an authorised collection point. For more information, contact the responsible administrative offices. Take care not to spill any hydraulic oil. Take measures to prevent spills of hydraulic oil (oil-tight tarp, catch pan).

---

#### ***Proceed as follows:***

- ▶ Clean the machine of coarse dirt.
- ▶ Lower the platform completely.
- ▶ Disconnect the machine from the mains electricity supply.

*The machine can now be transported (Chap. 4, page 18).*

## 9 Maintenance and inspections

### 9.1 Basic safety instructions



#### CAUTION

##### Hydraulic oils, lubricants and cleansers

Irritation or chemical burning of eyes, skin or respiratory tract

- Observe the safety instructions of the manufacturer.
  - Use personal protective equipment.
  - Use a breathing protection mask if necessary.
  - Avoid contact with the skin. Should contact with skin arise, wash thoroughly.
  - In the event of contact with eyes, rinse and consult a physician.
- 



#### NOTICE

##### Foreign objects in the danger zone (*Fig. 3-1, page 14*)

Damage to the machine

- Remove any foreign objects from the danger zone.
- 

##### ***Before any maintenance work or inspections***

- ▶ Chap. 3 "Basic safety instructions", page 8 should be read.
- ▶ Block unauthorised persons from accessing the work area of the machine.
- ▶ Attach or erect a notice sign prohibiting switching on the machine and informing that the machine is undergoing maintenance.
- ▶ Remove the load.
- ▶ Secure the machine against unintended switching on.
- ▶ Have collection containers and oil-bonding agent ready to ensure that no hydraulic oils, lubricants or cleansers contaminate the floor or enter the sewer system.

*The preparations are completed.*

##### ***After any maintenance work or inspections***

- ▶ Remove all used materials, tools or other objects from the danger zone (*Fig. 3-1, page 14*).
- ▶ Check the machine according to the inspection list (*Chap. 9.6.3 "Inspection list", page 38*).
- ▶ Ensure that all safety devices are functioning flawlessly and without restriction (*Chap. 3.8 "Safety devices on the machine", page 15*).
- ▶ Dispose of hydraulic oil, lubricants and cleansers in accordance with environmental regulations.

*The work is completed.*

## 9.2 Maintenance schedule

What?	When?	Description
Clean the machine	as needed, at least 1x yearly	<i>Chap. 9.3, page30</i>
Inspect the sliding bearings	every 250 hours of operation	<i>Chap. 9.4, page31</i>
Check hydraulic oil level, fill up	at the yearly accident prevention inspection	<i>Chap. 9.5.1, page32</i>
Change hydraulic oil	initially after 50 hours of operation; thereafter every 500 hours of operation or every 2 years	<i>Chap. 9.5.2, page32</i>
Bleed hydraulic system	as needed	<i>Chap. 9.5.3, page32</i>
Check hydraulic hoses	yearly	<i>Chap. 9.5.4, page36</i>

## 9.3 Cleaning the machine



### WARNING

#### Electrical shock

Injury from electrical shock

- Protect the electrical system from penetration by water or other liquids.
- Ensure that no electrical cables become detached or damaged during work.

#### ***Cleaning the machine***

- ▶ Clean the machine.
- ▶ Maintain the notices on the machine in clean and legible condition. Replace them if necessary.
- ▶ Clean the running surfaces of the castors.

*The cleaning is completed.*



## 9.4 Inspecting the sliding bearings

### *Inspecting the sliding bearings*

► Perform a visual check for wear (*Fig. 9-1, page 31*).

*The inspection is completed.*

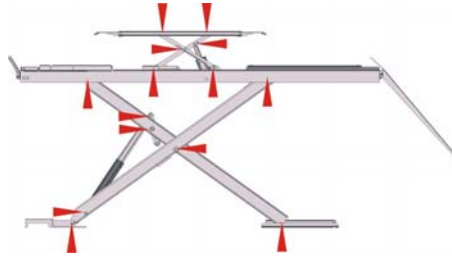

*Fig. 9-1 Bearing locations on the machine*

## 9.5 Servicing the hydraulic system



---

The handling and disposal of mineral-based oils is subject to legal regulations. Bring used oil to an authorised collection point. For more information, contact the responsible administrative offices. Take care not to spill any hydraulic oil. Take measures to prevent spills of hydraulic oil (oil-tight tarp, catch pan).

---



---

The hydraulic unit was filled with "Total Biohydran TMP 46" hydraulic oil (data sheet in appendix).

Alternatively, the following can be used:

- BP Biohyd SE 46
  - Fuchs Plantohyd 46S
  - Esso hydraulic oil HE 46
  - Total Equivis UVS 46
  - Shell Naturelle HF-E 46
-

### 9.5.1 Checking the hydraulic oil level

#### ***Checking the hydraulic oil level***

- ▶ Lower the platform completely.
- ▶ The oil level should lie approximately 2 cm under the fill opening.
- ▶ Top up the oil if needed.

*The check of the hydraulic oil level is completed.*

### 9.5.2 Changing the hydraulic oil

#### ***Changing the hydraulic oil***

- ▶ Raise the platform and secure it.
- ▶ Place oil collection containers under the hydraulic cylinders.
- ▶ Detach the hydraulic hoses on the hydraulic cylinders and place the open ends in the oil collection containers.
- ▶ Press the «Lift» control on the control device (*Fig. 7-1, page 25*) until no more hydraulic oil runs out of the hoses.
- ▶ Reattach the hydraulic hoses to the hydraulic cylinders.
- ▶ Remove the bleeder screw from the tank.
- ▶ Fill up the hydraulic oil. Fill quantity: *Chap. 2.3 "Technical data", page 7*.
- ▶ Screw the bleeder screw on the tank.
- ▶ Bleed the hydraulic system (*Chap. 9.5.3 "Bleeding the hydraulic system", page 32*).

*The hydraulic oil change is completed.*

### 9.5.3 Bleeding the hydraulic system

Aerate the hydraulic system after changing the hydraulic oil or after resolving a malfunction.

- The aeration procedures should be performed by at least two (preferably three) persons.
- During the aeration procedures, hydraulic oil may need to be refilled.

#### ***Aerating the main lifting unit***

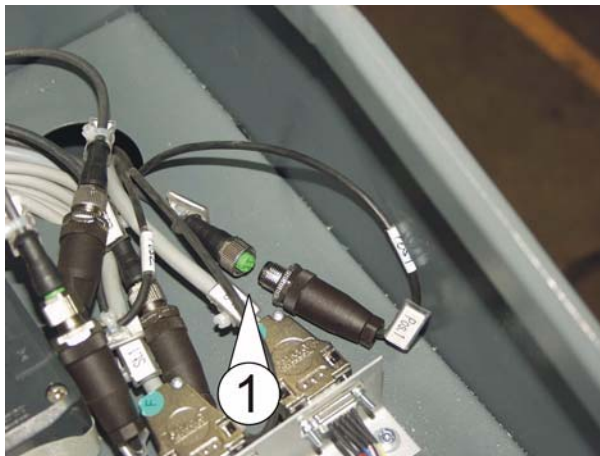

*Fig. 9-2 Plug pos. 1*

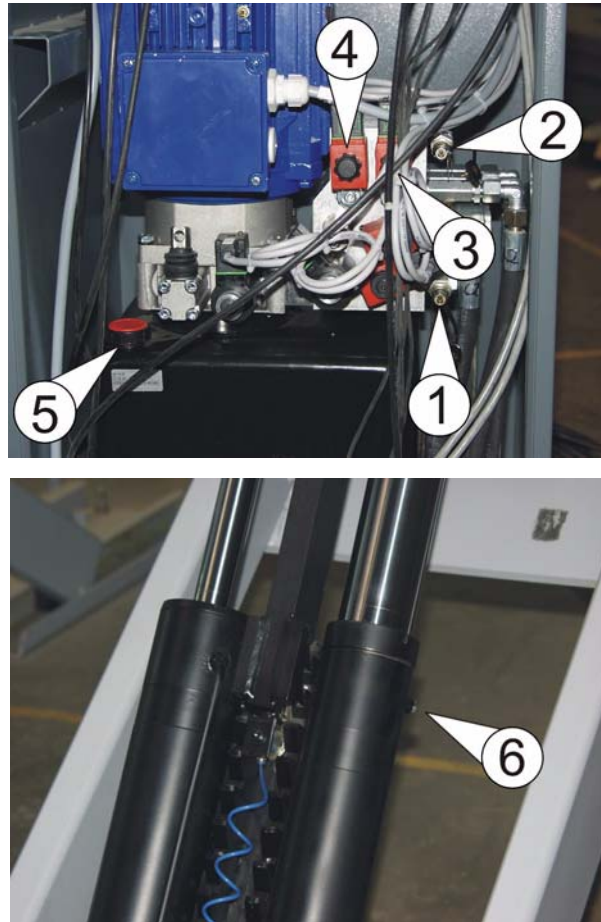

Fig. 9-3 Hydraulic

- ▶ Set the «Main lifting unit / Wheel-free lift» control (Fig. 7-1, page 25) to "Wheel-free lift".
- ▶ Open valves 1 and 2 (Fig. 9-3, page 33) by four revolutions.
- ▶ Detach plug at pos. 1 (Fig. 9-2, page 32). This will deactivate the "top position" sensor.
- ▶ Raise the platform to its furthest height.
- ▶ Press the «Lower to latched position» control to set the platform down in the latched position.
- ▶ Carefully unscrew the bleeder screws (6) on both slave hydraulic cylinders. The pressure thereby decreases and the oil-air mixture escapes.
- ▶ Screw in the bleeder screws (6) until they are about halfway screwed in (about 3 revolutions).
- ▶ Carefully operate the «Lift» control (inching mode) until both platforms have reached the mechanical stop.
- ▶ Press the «Lower to latched position» control for about 1 s to relieve the excess pressure.
- ▶ Close valves 1 and 2.
- ▶ Press the «Lower» control and lower the platform down completely. The air thereby escapes from the hydraulic tank. This will generate some noise.
- ▶ Hold the «Lower» control depressed for at least one additional minute.

## Maintenance and inspections

---

- ▶ Repeat the following steps until the synchronisation of the platforms is achieved:
  - ▶ Open valves 1 and 2 by four revolutions.
  - ▶ Set the platform down on the rests («Lower to latched position» control).
  - ▶ Unscrew the bleeder screws (6) on the hydraulic cylinders approximately 3 to 4 revolutions and allow the air to escape.
  - ▶ Carefully operate the «Lift» control (inching mode) until both platforms have reached the mechanical stop.
  - ▶ Tighten the bleeder screws (6).
  - ▶ Press the «Lower to latched position» control for about 1 s to relieve the excess pressure.
  - ▶ Close valves 1 and 2.
- ▶ Reattach plug at pos. 1.

*The aeration of the hydraulic system is completed.*

### Aerating the hydraulic system of the wheel-free lift (LT/LTAT version only)

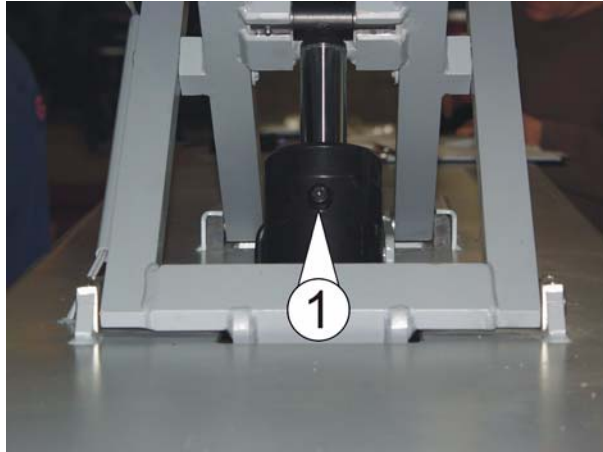

Fig. 9-4 Bleeding screw on wheel-free lift

- ▶ Lower the wheel-free lift.
- ▶ Move the main lifting unit to a midway working position and set it down on the safety latches.
- ▶ Carefully unscrew the hydraulic hoses (which may still be under pressure) from the wheel-free lift cylinders and place in a suitable collection container.
- ▶ Switch off the synchronisation monitor (turn on switch S9 in the control column). The control light flashes.
- ▶ Set the «Main lifting unit / Wheel-free lift» control (Fig. 7-1, page 25) to "Wheel-free lift".
- ▶ Press the «Lift» control until oil flows from the hose without bubbles.
- ▶ Attach the hydraulic hose on the piston side (bottom connection) of the master cylinder.
- ▶ Press the «Lift» control; the master wheel-free lift raises. Carefully move it into the end position.
- ▶ Switch on the filling valve Y7 (switch S8 in the control column). The control light flashes.
- ▶ Press the «Lift» control until oil flows out of the hoses; the master/slave connection hoses are filled.
- ▶ Mount the hydraulic hoses on the cylinder (master/slave connection).
- ▶ Press the «Lift» control; the slave wheel-free lift raises. Carefully move it into the end position. Oil may run out of the upper line as it is raised.
- ▶ Switch off the filling valve Y7 (switch S8 in the control column).
- ▶ Press the «Lower to latched position» control; the wheel-free lifts lower into the latched position.
- ▶ Place a suitable collection container under the master cylinder.
- ▶ Carefully unscrew the bleeder screw on the master cylinder. A mixture of oil and air escapes and the slave wheel-free lift lowers into the latched position.
- ▶ Screw in the bleeder screw halfway.
- ▶ Carefully operate the «Lift» control (inching mode) until oil flows out of the cylinder, then carefully continue raising it until the upper stop is reached.
- ▶ Switch on the filling valve Y7 (switch S8 in the control column). The control light flashes since the synchronisation monitor (switch S9) is still switched off.

- ▶ Carefully operate the «Lift» control (inching mode) until the slave cylinder reaches the stop.
- ▶ Switch off the filling valve Y7 (switch S8 in the control column).
- ▶ Repeat the following steps until the synchronisation of the wheel-free lifts is achieved:
  - ▶ Press the «Lower» control until both wheel-free lifts are completely lowered.
  - ▶ Press the «Lift» control until both wheel-free lifts are at the upper stop.
  - ▶ Press the «Lower to latched position» control; the master wheel-free lift lowers into the latched position.
  - ▶ Unscrew the bleeder screw on the master cylinder 3-4 revolutions until oil escapes; the slave wheel-free lift lowers into the latched position.
  - ▶ Tighten the bleeder screw.
  - ▶ Press the «Lift» control and check the synchronisation.
- ▶ Switch off the synchronisation monitor (turn off switch S9 in the control column). The control light is now continuously lit.

*The aeration of the wheel-free lift hydraulic system is completed.*

### 9.5.4 Checking the hydraulic hoses



---

For hydraulic hoses, a yearly inspection of operationally safe condition is prescribed. The inspection must be performed by a qualified and authorised specialist!

Hydraulic hoses conforming to DIN EN 853/2SN or DIN EN 856/4SP are built into the machine.

---

#### **Checking the hydraulic hoses**

- ▶ Perform a visual check of the hydraulic hoses:
  - ▶ Is any damage on the exterior, such as cracks, kinks, cuts, stripped points, areas of abrasion, brittleness, etc., detectable?
  - ▶ Are there any deformations of the hose in either depressurised or pressurised condition?
  - ▶ Are there any leaks between hose and fittings?
  - ▶ Does the hose become detached from the fittings?
- ▶ Replace hydraulic hoses if damage is detected, but after every 6 years at the latest.

*The inspection is completed.*

## 9.6 Inspections

### 9.6.1 Regular inspections

Regular inspections of the machine are to be performed by a qualified and authorised specialist at intervals of a year at the longest.



---

In Germany, inspection according to GUV-G 945 must be carried out. For this, use the inspection log book in the appendix of this operating manual.

---

### ***Performing the inspection***

- ▶ Copy the inspection list (*Chap. 9.6.3 "Inspection list", page 38*).
- ▶ Inspect every item and check it off if OK.
- ▶ Only put the machine back into operation if all points have been checked off.
- ▶ After completing the inspection, file the inspection list behind the appendix in this operating manual.

*The inspection is completed.*

### **9.6.2 Additional inspections**

Additional inspections of the machine are to be performed by a qualified and authorised specialist after each servicing and every repair of a malfunction.

An additional inspection is likewise required if the machine is to be restarted after being temporarily put out of service.



---

In Germany, inspection according to GUV-G 945 must be carried out. For this, use the inspection log book in the appendix of this operating manual.

---

### ***Performing the inspection***

- ▶ Copy the inspection list (*Chap. 9.6.3 "Inspection list", page 38*).
- ▶ Inspect every item and check it off if OK.
- ▶ Only put the machine back into operation if all points have been checked off.
- ▶ After completing the inspection, file the inspection list behind the appendix in this operating manual.

*The inspection is completed.*

### 9.6.3 Inspection list

<b>Sequential no.:</b>	
<b>Machine type:</b>	
<b>Machine no.:</b>	
<b>Inspector:</b>	

<b>Mechanical system</b>	
	Cylinder studs secured
	Scissors bolts secured
	Machine in clean condition
	Notices present and legible
	Welded points undamaged
	All screw connections are tight

<b>Hydraulic system</b>	
	No leaks in the hydraulic system
	Oil level is sufficient ( <i>Chap. 9.5.1, page32</i> )
	No damage of the hoses
	Hydraulic hoses not more than 6 years old
	Machine holds load at least 10 minutes in the highest position

<b>Electrical system</b>	
	Cables and cable grips tight
	Cables are secured
	No damage of the cables
	Upper position sensor stops the lifting motion
	Euro Stop sensor stops the lowering motion

All functions tested with no problems

-----

Date, Signature



## 10 Help for malfunctions



Please contact our customer service department. This prevents damage due to improperly performed work, saves time and avoids unnecessary costs.

### 10.1 Machine does not lift

Cause	Solution
Machine overloaded	Reduce the load
Leak in hydraulic system	<ul style="list-style-type: none"> <li>• Tighten screw connections</li> <li>• Reseal hydraulic cylinders</li> <li>• Replace hydraulic cylinders</li> <li>• Replace hydraulic hoses</li> </ul>
Pump does not build up any pressure	Replace hydraulic unit
Motor turning in wrong direction	Check the rotational direction of the voltage supply (only for rotary current) Factory supplies a right-rotating field
Top sensor position was reached	Lower platform
Switching valve defective	Replace switching valve
Solenoid on lowering valve defective	Replace the solenoid
Lowering valve defective	Replace lowering valve
Solenoid valve plug defective	Replace solenoid valve plug
Controller fuse defective	Replace controller fuse

### 10.2 Machine does not reach the full lift height

Cause	Solution
Oil level too low	Top up oil
Sensor not correctly set	Adjust sensor

### 10.3 Electric motor does not run

Cause	Solution
Current supply interrupted	<ul style="list-style-type: none"> <li>• Check supply line</li> <li>• Check fuse</li> <li>• Check motor protection switch</li> </ul>
Motor defective	Replace hydraulic unit

#### 10.4 Machine does not lower (completely down)

Cause	Solution
Obstacle (dirt) in the area of the roller bearings	Clean the area of the roller bearings
Solenoid on lowering valve defective	Replace the solenoid
Lowering valve defective	Replace lowering valve
Solenoid valve plug defective	Replace solenoid valve plug
Controller fuse defective	Replace controller fuse
Line-break safety device triggered	Identify and replace the defective component

#### 10.5 Oil leak

Cause	Solution
Leak in hydraulic system	<ul style="list-style-type: none"><li>• Tighten screw connections</li><li>• Reseal hydraulic cylinders</li><li>• Replace hydraulic cylinders</li><li>• Replace hydraulic hoses</li></ul>

#### 10.6 Machine deflects heavily when load is changed

Cause	Solution
Air in hydraulic system	Bleed hydraulic system

## 11 Appendix

Mechanical components

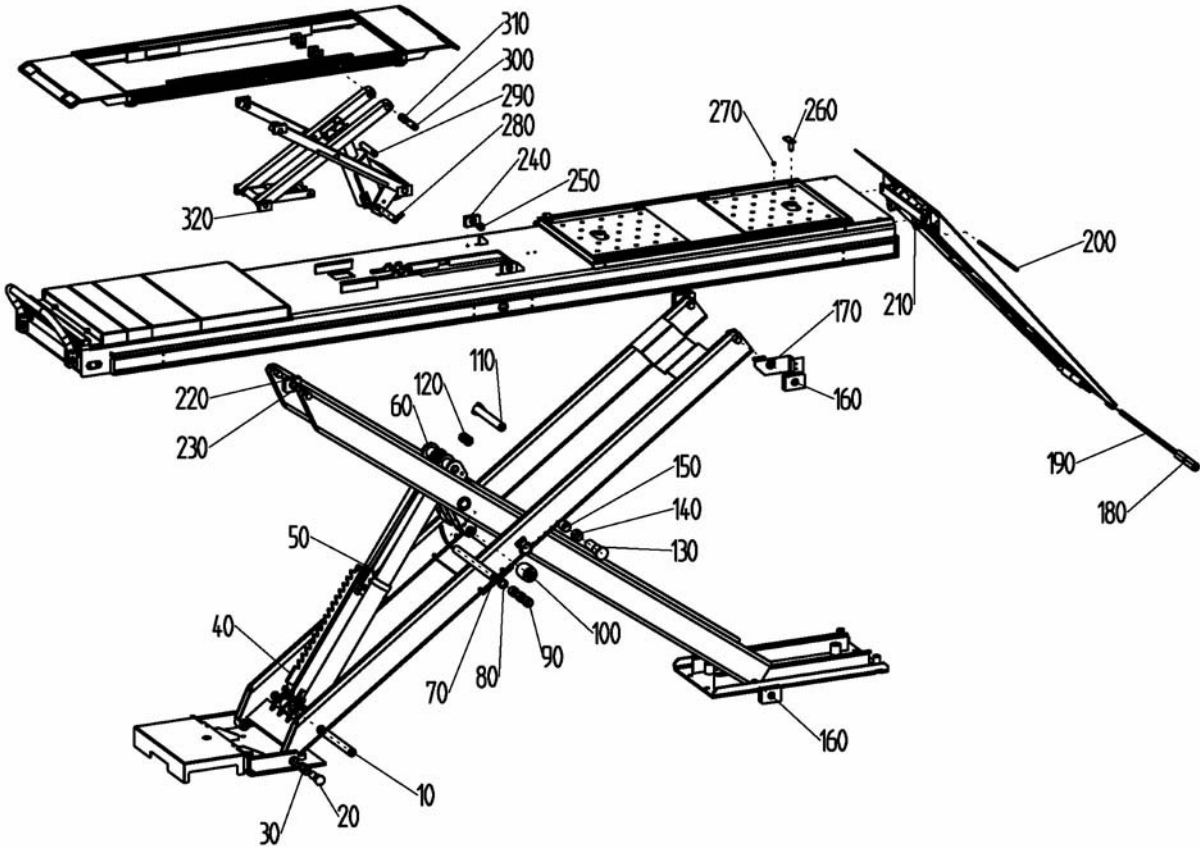

## Appendix

---

Pos.	Qty	Description	Art. no.	Note
10	1	Bearing pin	R435-4-2-1	
20	2	Bearing pin	12.16.410	
30	2	Bushing	10.02.297	
40	2	Gear rod	R400-ZY-1	
50	1	Lever	R435-6-1	
60	1	Rocker	50.51.012	
70	1	Bearing pin	12.16.448	
80	2	Bushing	10.02.287	
90	6	Bushing	10.02.297	
100	2	Castor	R435-5-2-1	
110	2	Bearing pin	52.82.085	
120	2	Bushing	10.02.287	
130	2	Bearing pin	10.16.405	
140	2	Bushing	10.02.294	
150	2	Bushing	10.02.284	
160	4	Sliding block	10.28.049	
170	1	E-chain	R435-1-2-3	
180	4	Castor	R435-1-4-3-1	
190	1	Axle	R435-1-4-3-2	
200	1	Axle	R435-1-4-3-4	
210	2	Base plate	R435-1-4-3-3	
220	2	Fixed bearing	R435-1-2-1	
230	2	Bushing	10.02.241	
240	2	Fixed bearing	R435-1-2-2	
250	2	Bushing	10.02.225	
260	2	Bolt	R435-1-6-6	
270	44	Ball	10.02.054	
280	1	Bearing pin	R435-7-4-2-1	
290	1	Bearing pin	12.16.406	
300	2	Bearing pin	R435-7-3-2-4	
310	4	Bushing	10.02.271	
320	4	Sliding block	R435-7-3-2-5	

Mechanical components

Pos. 32 ohne Darstellung  
 Pos. 32 without description

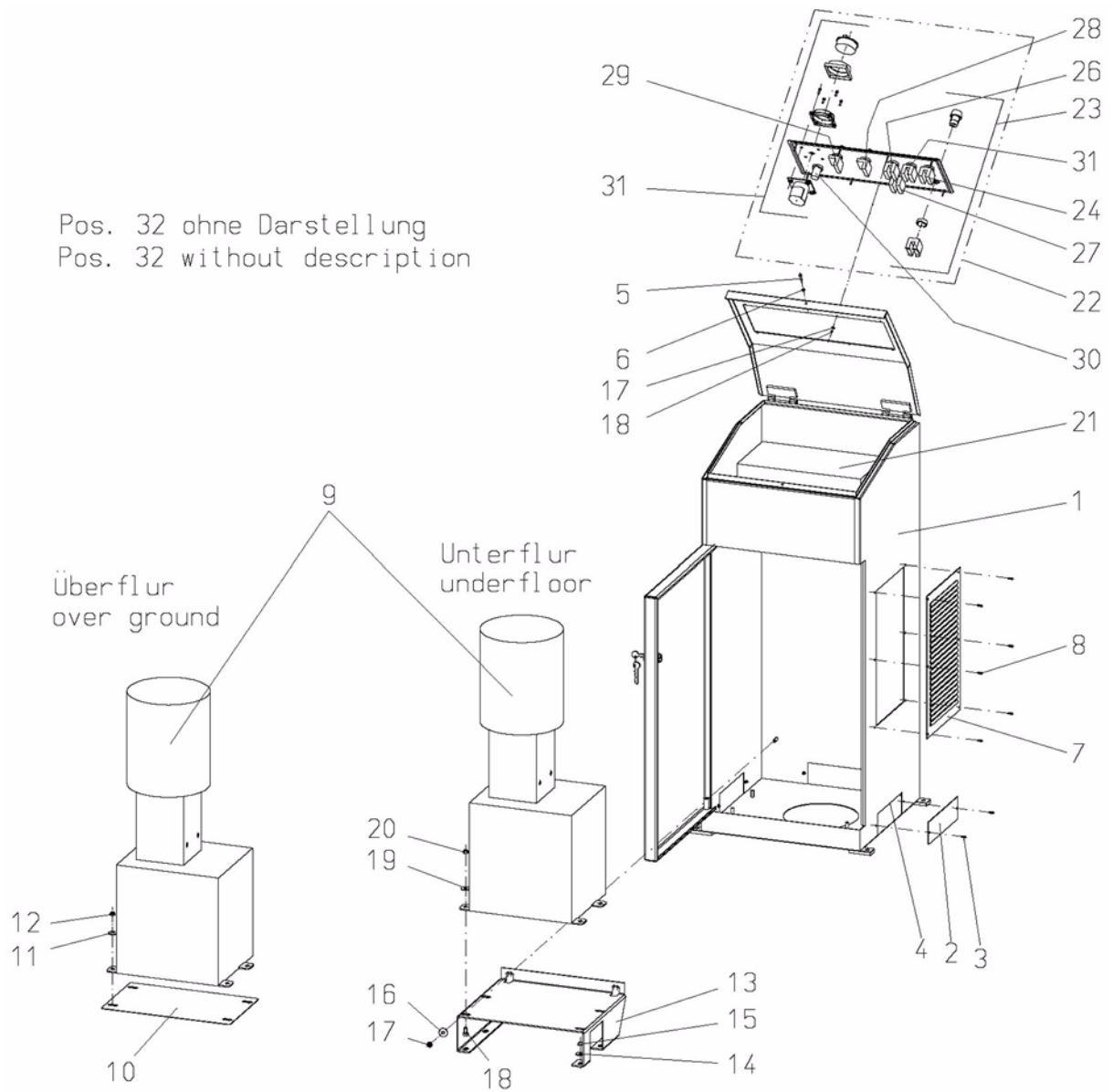

**ML 40/50 N**

Pos.	Qty	Description	Art. no.	Note
1	1	Control column	11.34.190	
2	2	Cover	56.81.029	
3	4	Thread grooving screw	12.54.112	DIN 7500-CM5x8-St-Z
4	1	Edge guard	55.38.078	290 mm
5	1	Cylinder screw	12.54.184	DIN 912-M6x30-10.9
6	1	Washer	12.40.040	ISO 7093-6-100HV
7	1	Louvered plate	56.91.352	
8	6	Thread grooving screw	12.54.112	DIN 7500-CM5x8-St-Z
9	1	Hydraulic unit	11.18.262	3.6 kW / 400 V
10	1	Cover plate	11.41.699	
11	4	Washer	12.40.076	ISO 7093-8-100HV
12	4	Locknut	12.55.042	DIN 985-M8-8
13	1	Unit riser plate	56.93.221	
14	4	Washer	12.40.076	ISO 7093-8-100HV
15	4	Locknut	12.55.042	DIN 985-M8-8
16	2	Washer	12.40.076	ISO 7093-8-100HV
17	2	Locknut	12.55.042	DIN 985-M8-8
18	4	Hexagon bolt	12.50.041	ISO 4017-M8x16-8.8
19	4	Washer	12.40.076	ISO 7093-8-100HV
20	4	Locknut	12.55.042	DIN 985-M8-8
21	1	Controller		consisting of pos. 25-35
22	1	Console plate	58.70.014	consisting of pos. 26-35
23	1	Lift key	10.30.572	
24	1	Lower key	10.30.573	
25	1	Lower key	10.30.573	Latched position
26	1	Key, black	10.30.586	Preset position I
27	0	Key, black	10.30.586	Preset position II
28	0	Toggle switch	10.30.587	Switch for wheel-free lift
29	0	Toggle switch	10.30.576	Moving platform locking device
30	1	Indicator light, white	10.30.576	
31	1	Main switch	10.30.574	
32	3	Screw plug	10.30.588	Dummy plug

**ML 40/50 N with preset position II**

Pos.	Qty	Description	Art. no.	Note
1	1	Control column	11.34.190	
2	2	Cover	56.81.029	
3	4	Thread grooving screw	12.54.112	DIN 7500-CM5x8-St-Z
4	1	Edge guard	55.38.078	290 mm
5	1	Cylinder screw	12.54.184	DIN 912-M6x30-10.9
6	1	Washer	12.40.040	ISO 7093-6-100HV
7	1	Louvered plate	56.91.352	
8	6	Thread grooving screw	12.54.112	DIN 7500-CM5x8-St-Z
9	1	Hydraulic unit	11.18.262	3.6 kW / 400 V
10	1	Cover plate	11.41.699	
11	4	Washer	12.40.076	ISO 7093-8-100HV
12	4	Locknut	12.55.042	DIN 985-M8-8
13	1	Unit riser plate	56.93.221	
14	4	Washer	12.40.076	ISO 7093-8-100HV
15	4	Locknut	12.55.042	DIN 985-M8-8
16	2	Washer	12.40.076	ISO 7093-8-100HV
17	2	Locknut	12.55.042	DIN 985-M8-8
18	4	Hexagon bolt	12.50.041	ISO 4017-M8x16-8.8
19	4	Washer	12.40.076	ISO 7093-8-100HV
20	4	Locknut	12.55.042	DIN 985-M8-8
21	1	Controller		consisting of pos. 25-35
22	1	Console plate	58.70.010	consisting of pos. 26- 35
23	1	Lift key	10.30.572	
24	1	Lower key	10.30.573	
25	1	Lower key	10.30.573	Latched position
26	1	Key, black	10.30.586	Preset position I
27	1	Key, black	10.30.586	Preset position II
28	0	Toggle switch	10.30.587	Switch for wheel-free lift
29	0	Toggle switch	10.30.576	Moving platform locking device
30	1	Indicator light, white	10.30.576	
31	1	Main switch	10.30.574	
32	2	Screw plug	10.30.588	Dummy plug



## ML 40/50 NAT

Pos.	Qty	Description	Art. no.	Note
1	1	Control column	11.34.190	
2	2	Cover	56.81.029	
3	4	Thread grooving screw	12.54.112	DIN 7500-CM5x8-St-Z
4	1	Edge guard	55.38.078	290 mm
5	1	Cylinder screw	12.54.184	DIN 912-M6x30-10.9
6	1	Washer	12.40.040	ISO 7093-6-100HV
7	1	Louvered plate	56.91.352	
8	6	Thread grooving screw	12.54.112	DIN 7500-CM5x8-St-Z
9	1	Hydraulic unit	11.18.262	3.6 kW / 400 V
10	1	Cover plate	11.41.699	
11	4	Washer	12.40.076	ISO 7093-8-100HV
12	4	Locknut	12.55.042	DIN 985-M8-8
13	1	Unit riser plate	56.93.221	
14	4	Washer	12.40.076	ISO 7093-8-100HV
15	4	Locknut	12.55.042	DIN 985-M8-8
16	2	Washer	12.40.076	ISO 7093-8-100HV
17	2	Locknut	12.55.042	DIN 985-M8-8
18	4	Hexagon bolt	12.50.041	ISO 4017-M8x16-8.8
19	4	Washer	12.40.076	ISO 7093-8-100HV
20	4	Locknut	12.55.042	DIN 985-M8-8
21	1	Controller		consisting of pos. 25-35
22	1	Console plate	58.70.012	consisting of pos. 26- 35
23	1	Lift key	10.30.572	
24	1	Lower key	10.30.573	
25	1	Lower key	10.30.573	Latched position
26	1	Key, black	10.30.586	Preset position I
27	0	Key, black	10.30.586	Preset position II
28	0	Toggle switch	10.30.587	Switch for wheel-free lift
29	1	Toggle switch	10.30.576	Moving platform locking device
30	1	Indicator light, white	10.30.576	
31	1	Main switch	10.30.574	
32	2	Screw plug	10.30.588	Dummy plug

**ML 40/50 NAT with preset position II**

Pos.	Qty	Description	Art. no.	Note
1	1	Control column	11.34.190	
2	2	Cover	56.81.029	
3	4	Thread grooving screw	12.54.112	DIN 7500-CM5x8-St-Z
4	1	Edge guard	55.38.078	290 mm
5	1	Cylinder screw	12.54.184	DIN 912-M6x30-10.9
6	1	Washer	12.40.040	ISO 7093-6-100HV
7	1	Louvered plate	56.91.352	
8	6	Thread grooving screw	12.54.112	DIN 7500-CM5x8-St-Z
9	1	Hydraulic unit	11.18.262	3.6 kW / 400 V
10	1	Cover plate	11.41.699	
11	4	Washer	12.40.076	ISO 7093-8-100HV
12	4	Locknut	12.55.042	DIN 985-M8-8
13	1	Unit riser plate	56.93.221	
14	4	Washer	12.40.076	ISO 7093-8-100HV
15	4	Locknut	12.55.042	DIN 985-M8-8
16	2	Washer	12.40.076	ISO 7093-8-100HV
17	2	Locknut	12.55.042	DIN 985-M8-8
18	4	Hexagon bolt	12.50.041	ISO 4017-M8x16-8.8
19	4	Washer	12.40.076	ISO 7093-8-100HV
20	4	Locknut	12.55.042	DIN 985-M8-8
21	1	Controller		consisting of pos. 25-35
22	1	Console plate	58.70.008	consisting of pos. 26- 35
23	1	Lift key	10.30.572	
24	1	Lower key	10.30.573	
25	1	Lower key	10.30.573	Latched position
26	1	Key, black	10.30.586	Preset position I
27	1	Key, black	10.30.586	Preset position II
28	0	Toggle switch	10.30.587	Switch for wheel-free lift
29	1	Toggle switch	10.30.576	Moving platform locking device
30	1	Indicator light, white	10.30.576	
31	1	Main switch	10.30.574	
32	1	Screw plug	10.30.588	Dummy plug

**ML 40/50 LT**

Pos.	Qty	Description	Art. no.	Note
1	1	Control column	11.34.190	
2	2	Cover	56.81.029	
3	4	Thread grooving screw	12.54.112	DIN 7500-CM5x8-St-Z
4	1	Edge guard	55.38.078	290 mm
5	1	Cylinder screw	12.54.184	DIN 912-M6x30-10.9
6	1	Washer	12.40.040	ISO 7093-6-100HV
7	1	Louvered plate	56.91.352	
8	6	Thread grooving screw	12.54.112	DIN 7500-CM5x8-St-Z
9	1	Hydraulic unit	11.18.261	4 kW / 400 V
10	1	Cover plate	11.41.699	
11	4	Washer	12.40.076	ISO 7093-8-100HV
12	4	Locknut	12.55.042	DIN 985-M8-8
13	1	Unit riser plate	56.93.221	
14	4	Washer	12.40.076	ISO 7093-8-100HV
15	4	Locknut	12.55.042	DIN 985-M8-8
16	2	Washer	12.40.076	ISO 7093-8-100HV
17	2	Locknut	12.55.042	DIN 985-M8-8
18	4	Hexagon bolt	12.50.041	ISO 4017-M8x16-8.8
19	4	Washer	12.40.076	ISO 7093-8-100HV
20	4	Locknut	12.55.042	DIN 985-M8-8
21	1	Controller		consisting of pos. 25-35
22	1	Console plate	58.70.013	consisting of pos. 26- 35
23	1	Lift key	10.30.572	
24	1	Lower key	10.30.573	
25	1	Lower key	10.30.573	Latched position
26	1	Key, black	10.30.586	Preset position I
27	0	Key, black	10.30.586	Preset position II
28	1	Toggle switch	10.30.587	Switch for wheel-free lift
29	0	Toggle switch	10.30.576	Moving platform locking device
30	1	Indicator light, white	10.30.576	
31	1	Main switch	10.30.574	
32	2	Screw plug	10.30.588	Dummy plug

**ML 40/50 LT with preset position II**

Pos.	Qty	Description	Art. no.	Note
1	1	Control column	11.34.190	
2	2	Cover	56.81.029	
3	4	Thread grooving screw	12.54.112	DIN 7500-CM5x8-St-Z
4	1	Edge guard	55.38.078	290 mm
5	1	Cylinder screw	12.54.184	DIN 912-M6x30-10.9
6	1	Washer	12.40.040	ISO 7093-6-100HV
7	1	Louvered plate	56.91.352	
8	6	Thread grooving screw	12.54.112	DIN 7500-CM5x8-St-Z
9	1	Hydraulic unit	11.18.261	4 kW / 400 V
10	1	Cover plate	11.41.699	
11	4	Washer	12.40.076	ISO 7093-8-100HV
12	4	Locknut	12.55.042	DIN 985-M8-8
13	1	Unit riser plate	56.93.221	
14	4	Washer	12.40.076	ISO 7093-8-100HV
15	4	Locknut	12.55.042	DIN 985-M8-8
16	2	Washer	12.40.076	ISO 7093-8-100HV
17	2	Locknut	12.55.042	DIN 985-M8-8
18	4	Hexagon bolt	12.50.041	ISO 4017-M8x16-8.8
19	4	Washer	12.40.076	ISO 7093-8-100HV
20	4	Locknut	12.55.042	DIN 985-M8-8
21	1	Controller		consisting of pos. 25-35
22	1	Console plate	58.70.009	consisting of pos. 26- 35
23	1	Lift key	10.30.572	
24	1	Lower key	10.30.573	
25	1	Lower key	10.30.573	Latched position
26	1	Key, black	10.30.586	Preset position I
27	1	Key, black	10.30.586	Preset position II
28	1	Toggle switch	10.30.587	Switch for wheel-free lift
29	0	Toggle switch	10.30.576	Moving platform locking device
30	1	Indicator light, white	10.30.576	
31	1	Main switch	10.30.574	
32	1	Screw plug	10.30.588	Dummy plug

**ML 40/50 LTAT**

Pos.	Qty	Description	Art. no.	Note
1	1	Control column	11.34.190	
2	2	Cover	56.81.029	
3	4	Thread grooving screw	12.54.112	DIN 7500-CM5x8-St-Z
4	1	Edge guard	55.38.078	290 mm
5	1	Cylinder screw	12.54.184	DIN 912-M6x30-10.9
6	1	Washer	12.40.040	ISO 7093-6-100HV
7	1	Louvered plate	56.91.352	
8	6	Thread grooving screw	12.54.112	DIN 7500-CM5x8-St-Z
9	1	Hydraulic unit	11.18.261	4 kW / 400 V
10	1	Cover plate	11.41.699	
11	4	Washer	12.40.076	ISO 7093-8-100HV
12	4	Locknut	12.55.042	DIN 985-M8-8
13	1	Unit riser plate	56.93.221	
14	4	Washer	12.40.076	ISO 7093-8-100HV
15	4	Locknut	12.55.042	DIN 985-M8-8
16	2	Washer	12.40.076	ISO 7093-8-100HV
17	2	Locknut	12.55.042	DIN 985-M8-8
18	4	Hexagon bolt	12.50.041	ISO 4017-M8x16-8.8
19	4	Washer	12.40.076	ISO 7093-8-100HV
20	4	Locknut	12.55.042	DIN 985-M8-8
21	1	Controller		consisting of pos. 25-35
22	1	Console plate	58.70.011	consisting of pos. 26- 35
23	1	Lift key	10.30.572	
24	1	Lower key	10.30.573	
25	1	Lower key	10.30.573	Latched position
26	1	Key, black	10.30.586	Preset position I
27	0	Key, black	10.30.586	Preset position II
28	1	Toggle switch	10.30.587	Switch for wheel-free lift
29	1	Toggle switch	10.30.576	Moving platform locking device
30	1	Indicator light, white	10.30.576	
31	1	Main switch	10.30.574	
32	1	Screw plug	10.30.588	Dummy plug

**ML 40/50 LTAT with preset position II**

Pos.	Qty	Description	Art. no.	Note
1	1	Control column	11.34.190	
2	2	Cover	56.81.029	
3	4	Thread grooving screw	12.54.112	DIN 7500-CM5x8-St-Z
4	1	Edge guard	55.38.078	290 mm
5	1	Cylinder screw	12.54.184	DIN 912-M6x30-10.9
6	1	Washer	12.40.040	ISO 7093-6-100HV
7	1	Louvered plate	56.91.352	
8	6	Thread grooving screw	12.54.112	DIN 7500-CM5x8-St-Z
9	1	Hydraulic unit	11.18.261	4 kW / 400 V
10	1	Cover plate	11.41.699	
11	4	Washer	12.40.076	ISO 7093-8-100HV
12	4	Locknut	12.55.042	DIN 985-M8-8
13	1	Unit riser plate	56.93.221	
14	4	Washer	12.40.076	ISO 7093-8-100HV
15	4	Locknut	12.55.042	DIN 985-M8-8
16	2	Washer	12.40.076	ISO 7093-8-100HV
17	2	Locknut	12.55.042	DIN 985-M8-8
18	4	Hexagon bolt	12.50.041	ISO 4017-M8x16-8.8
19	4	Washer	12.40.076	ISO 7093-8-100HV
20	4	Locknut	12.55.042	DIN 985-M8-8
21	1	Controller		consisting of pos. 25-35
22	1	Console plate	58.70.007	consisting of pos. 26- 35
23	1	Lift key	10.30.572	
24	1	Lower key	10.30.573	
25	1	Lower key	10.30.573	Latched position
26	1	Key, black	10.30.586	Preset position I
27	1	Key, black	10.30.586	Preset position II
28	1	Toggle switch	10.30.587	Switch for wheel-free lift
29	1	Toggle switch	10.30.576	Moving platform locking device
30	1	Indicator light, white	10.30.576	
31	1	Main switch	10.30.574	
32	0	Screw plug	10.30.588	Dummy plug

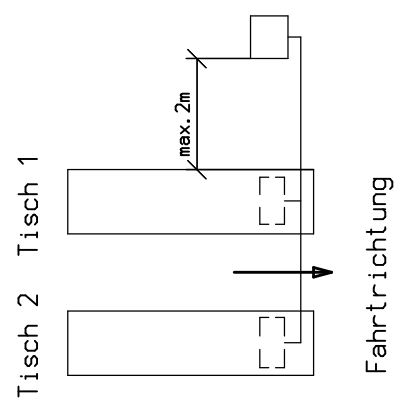
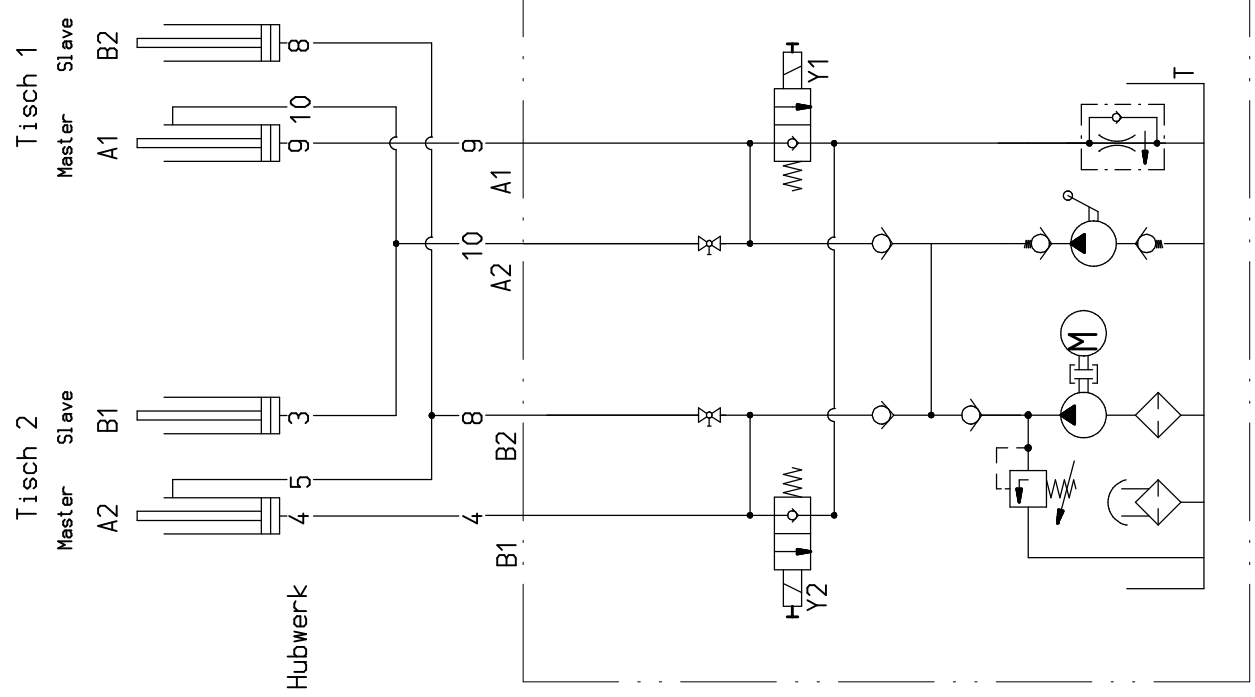

N / NAT		Masse ohne Toleranzangabe 150 13920-B		Maßstab: 1:5	
		Datum 07.02.2008		Name	
		Gepr.		Konradt	
		Norm			
		CAD: C:\384A\34ED.SZA			
1 Korrektur		14.04.2008		R.W.	
Zust.		Änderung		Name Urspr: R400-HY2_2	
		Datum		Ers. f.: R400-HY2_2	
				Ers. d.:	
<b>Hydraulikplan</b>				<b>15.33.831</b>	
ML40 / ML50				Blatt	

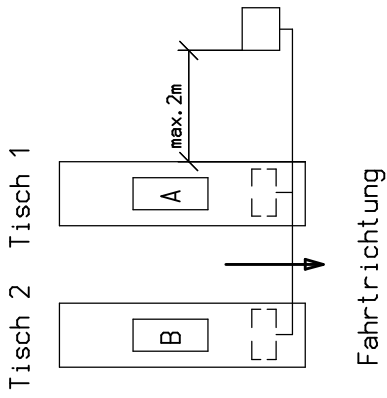
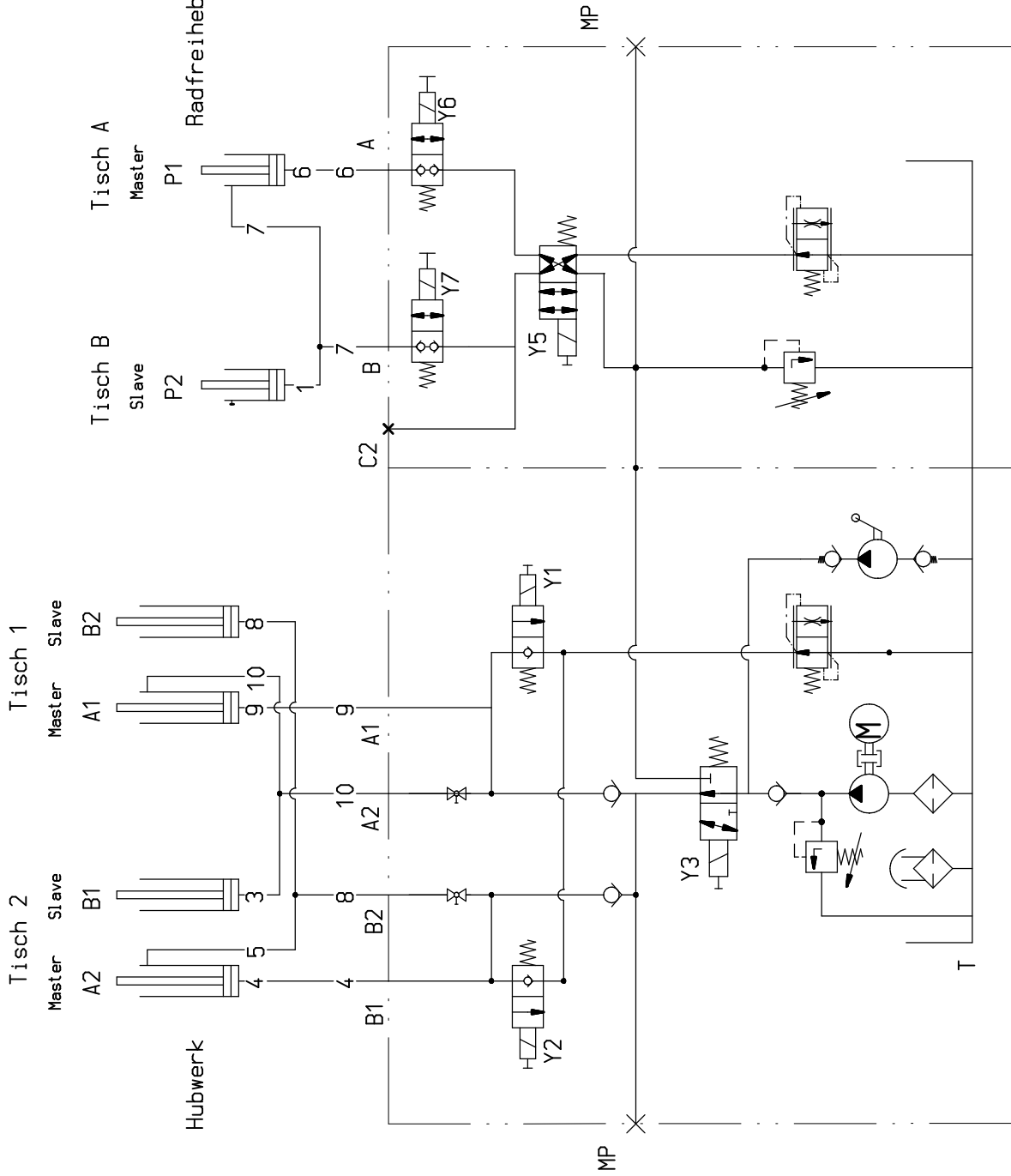

LT / LTAT		Maßstab: 1:5	
Bearb.	Datum	Name	
07.02.2008	07.02.2008	Kornadt	
Gepr.			
Norm			
cad: C:\FEE381B.SZA			
1 Korrektur		14.04.2008 R.W.	
Zust.	Änderung	Datum	
		Name	
Urspr: R400-HY2		Ers. d.:	
15.33.832		Blatt	

Schutzvermerk DIN 34 beachten!



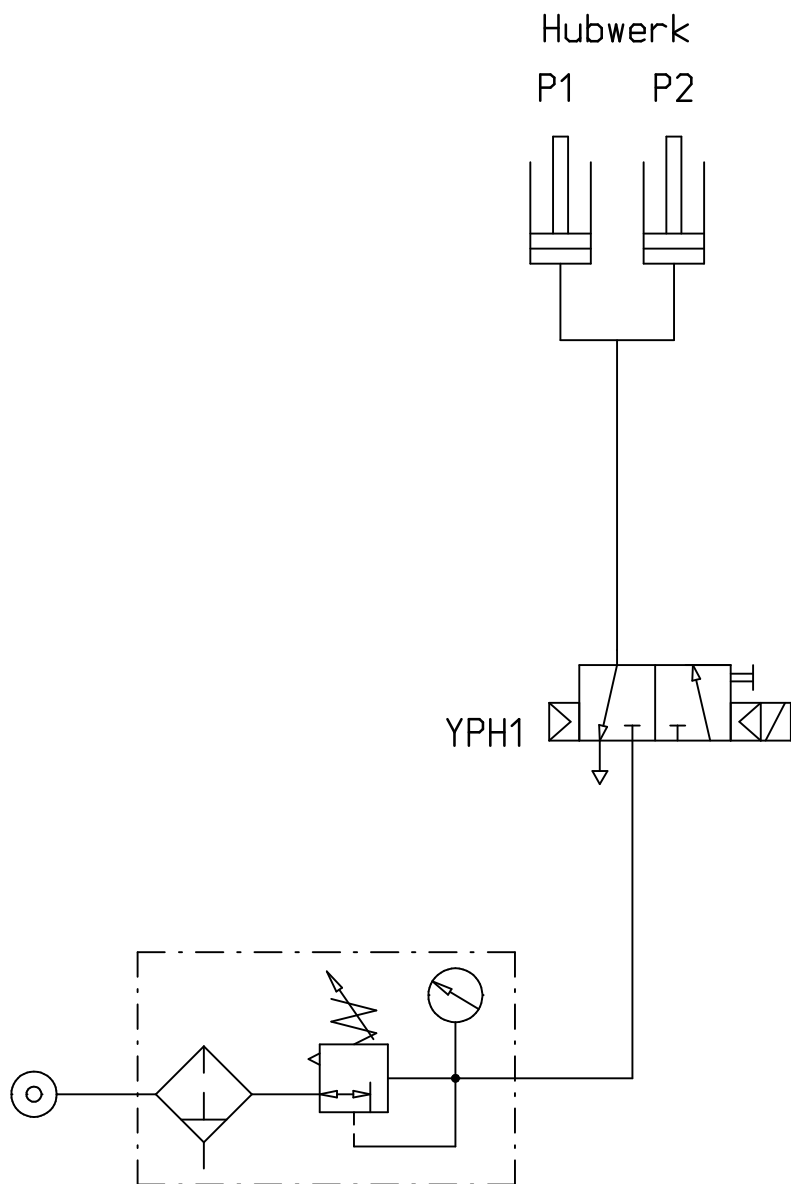

N / NAT				Maßstab: 1:1		
				<b>Pneumatikplan</b> ML40 / ML50 / M50  <b>15.33.833</b>		
		Datum	Name			
		Bearb.	05.03.2008			Konradt
		Gepr.				
		Norm				
		CAD: C: 9ED8C429. SZA				
					Blatt	
1	Korrektur	15.04.2008	R.W.			
Zust.	Änderung	Datum	Name	Urspr. R400-PN1	Ers. d.:	

**Schutzvermerk DIN 34 beachten !**

17.04.2008

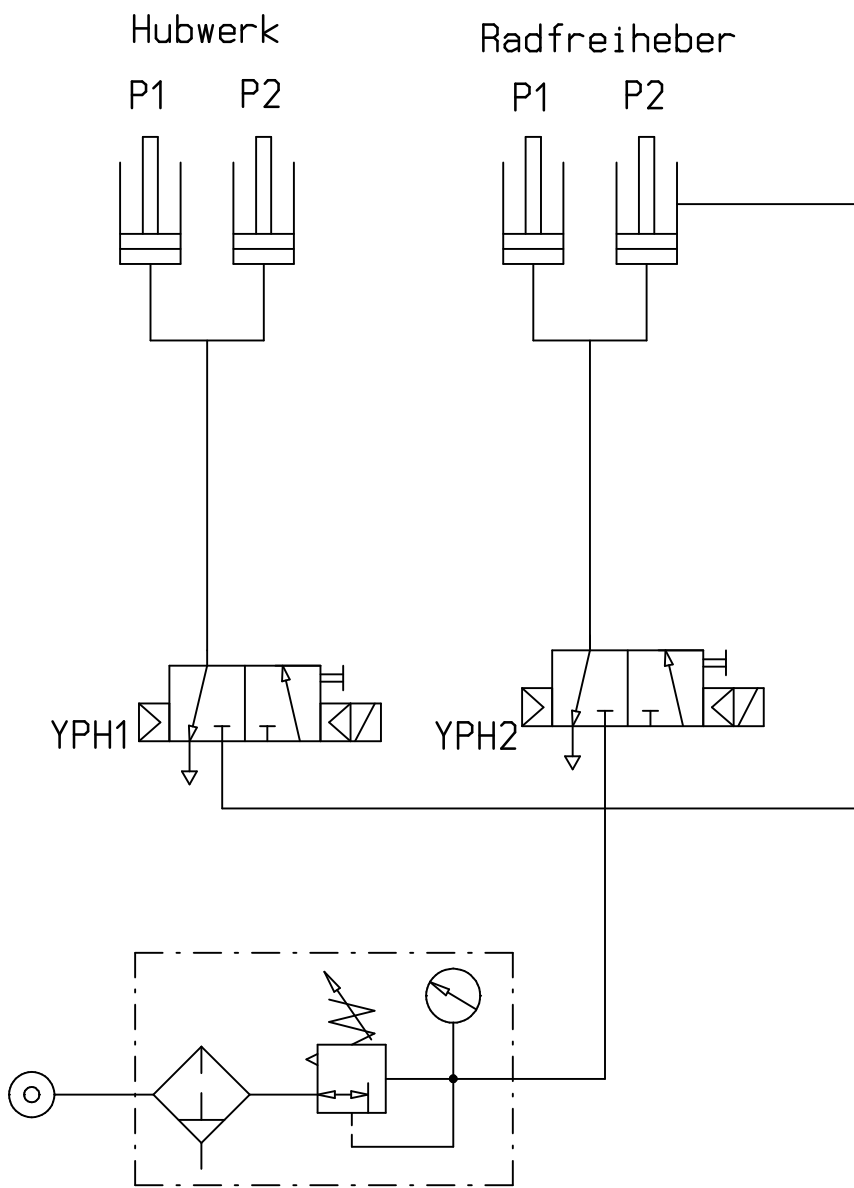

LT / LTAT			Maßstab: 1:1		
			Datum	Name	Pneumatikplan ML40 / ML50 / M50
		Bearb.	05.03.2008	Konradt	
		Gepr.			
		Norm			
			CAD: C: C79AB105.SZA		
					15.33.834
1	Korrektur	15.04.2008	R.W.		
Zust.	Änderung	Datum	Name	Urspr. R400-PN3	Ers. f.: R400-PN3
					Ers. d.:

Schutzvermerk DIN 34 beachten !

17.04.2008

Anschluß : 3 ~ PH 400 V / N / PE

terminal

Betriebsspannung : 400 V

supply voltage

Netzfrequenz : 50 Hz

supply frequency

Nennleistung : 4,0 KW

Nominal power

Nennstrom : 8,1 A

Nominal current

Steuerspannung : 24VDC

Control voltage

Spannung : 24VDC

Signal voltage

Sicherung : 16A

fuse

Zuleitungsquerschnitt : 1,5mm<sup>2</sup>

Line cross-section

Schutzart : IP 54

degree of protection

Geprüft nach : VDE 0113

Tested according to

Schutzvermerk nach DIN 34 beachten !

Erstellt mit ELCAD/AUCOPLAN (R) 7.4.0

# Elektro-Schaltpläne

Electrical circuit diagram

Auftraggeber : Blitz Rotary  
 Client  
 Hubtisch Ausführung : PKW Hebebühne  
 Lift table design  
 Typ : ML40/50 Serie  
 Type

R. Änderung	Datum	Name	Ursprung	Ersatz für	Ersatz durch	Deckblatt	Data sheet	ML40/50 Serie	Geräte-Nr.:	ML_40_50	Blatt	1
						1			/		1	Bl.
	21.04.2008	Schwarze			Blitz Rotary							

Schutzvermerk nach DIN 34 beachten !

Alle Leitungen ohne Querschnittsangaben sind H07VK gy 0,75 mm<sup>2</sup>

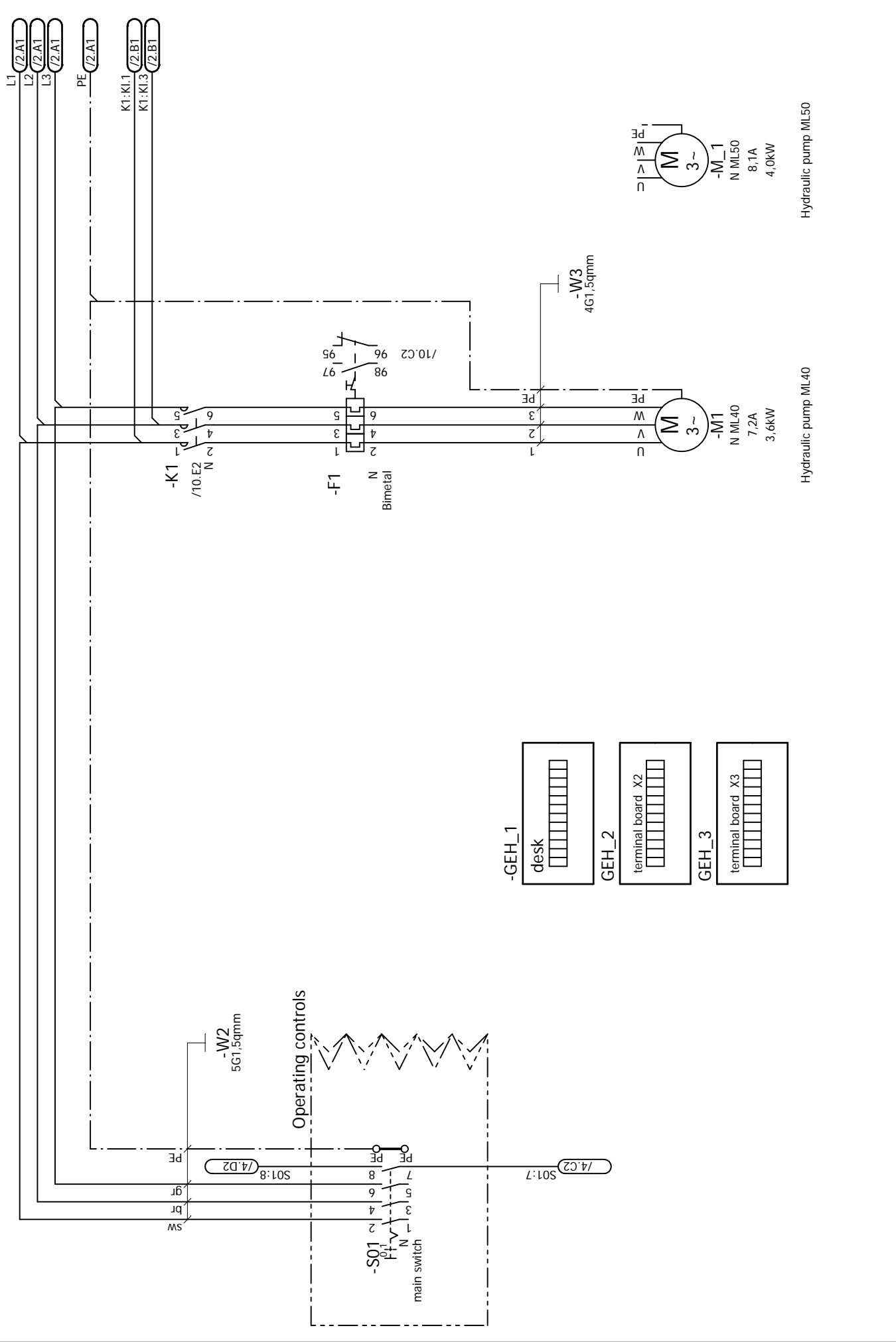

R. Änderung		Datum	Name	Ursprung		Ersatz für		Ersatz durch	
Blitz Rotary		Datum	21.04.2008	Blitz Rotary					
Bearbeiter		Schwarze							
Geprüft									
Norm									
Geräte-Nr.:		ML_40_50							
AB - Nr.:		/							
Stromlaufplan		1							
ML40/50 Serie									
Blatt 1		15							



R. Änderung	Datum	Name
Geprüft	Norm	Ursprung
Bearbeiter	Schwarze	Blitz Rotary
Datum	21.04.2008	Blitz Rotary

Ersatz für	Ersatz durch

Stromlaufplan	Logo mini controller	Logo add-on module
3		

AB - Nr.:	/	Geräte-Nr.:	ML_40_50

Stromlaufplan	ML40/50 Serie
3	

Blatt 3	15
Bl.	8

### Logo mini controller

### Logo add-on module

Terminal	Terminal	Terminal	Terminal	Terminal	Terminal	Terminal	Terminal	Terminal	Terminal	Terminal	Terminal	Terminal	Terminal	Terminal	Terminal	Terminal															
11 /7.D2	12 /7.D3	13 /7.D3	14 /7.D4	15 /7.D5	16 /7.D6	17 /7.D7	18 /7.D8	11 /8.D3	12 /8.D4	13 /8.D5	14 /8.D7	11 /9.D3	12 /9.D4	13 /9.D5	14 /9.D7	Q1 /10.B2	Q2 /10.B4	Q3 /10.B5	Q4 /10.B7	Q1 /11.B2	Q2 /11.B4	Q3 /11.B5	Q4 /11.B7	Q1 /12.B2	Q2 /12.B4	Q3 /12.B5	Q4 /12.B7	Q1 /12.B2	Q2 /12.B4	Q3 /12.B5	Q4 /12.B7
8xDI/4xDO 24VDC								4xDI/4xDO 24VDC								4xDI/4xDO 24VDC															
								<input type="checkbox"/> RUN/STOP								<input type="checkbox"/> RUN/STOP															



-A1  
L M

-A2  
L M

-A3  
L M

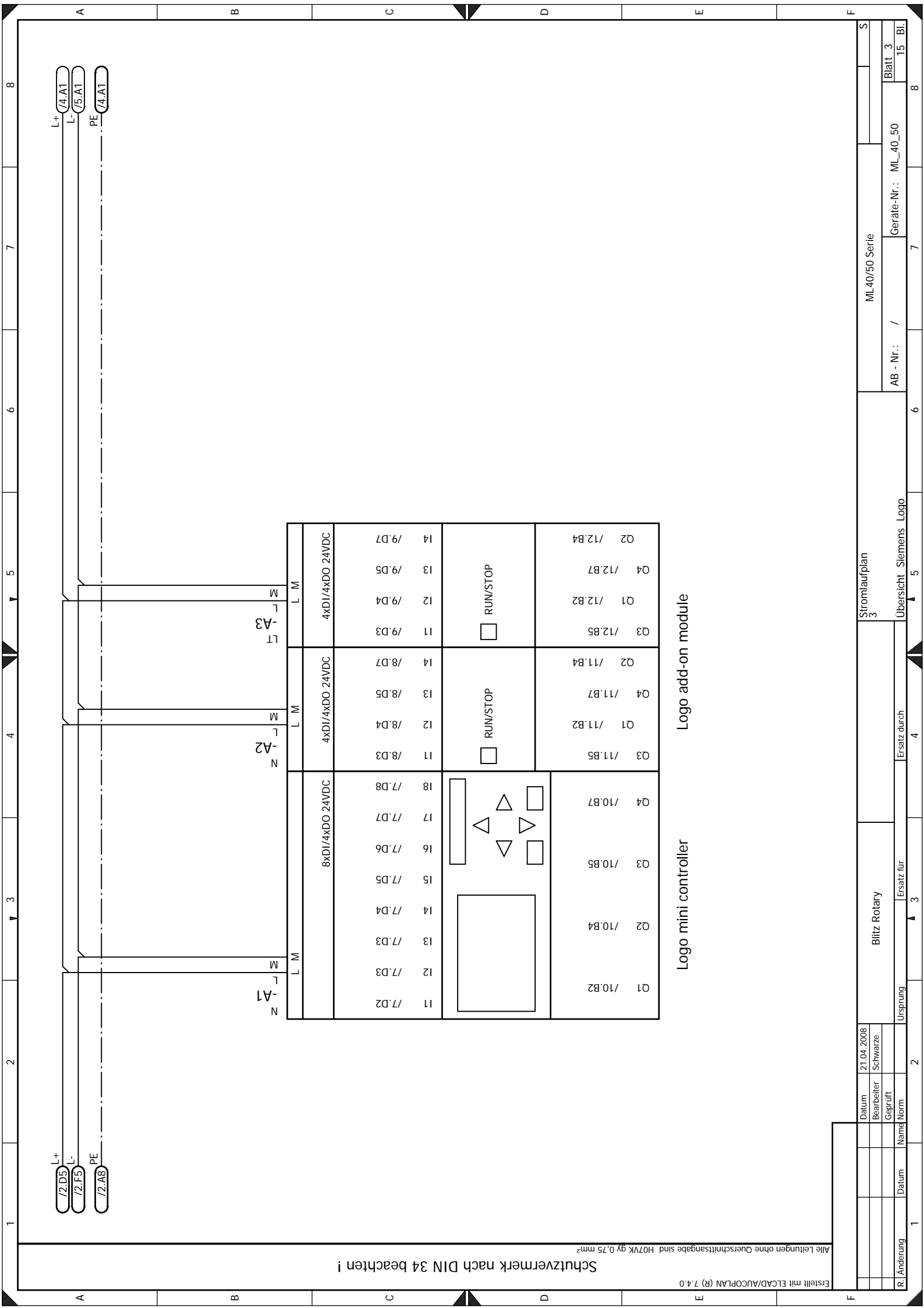



# Schutzvermerk nach DIN 34 beachten !

Alle Leitungen ohne Querschnittsangaben sind H07VK gy 0,75 mm<sup>2</sup>

Erstellt mit ELCAD/AUCOPLAN (R) 7.4.0

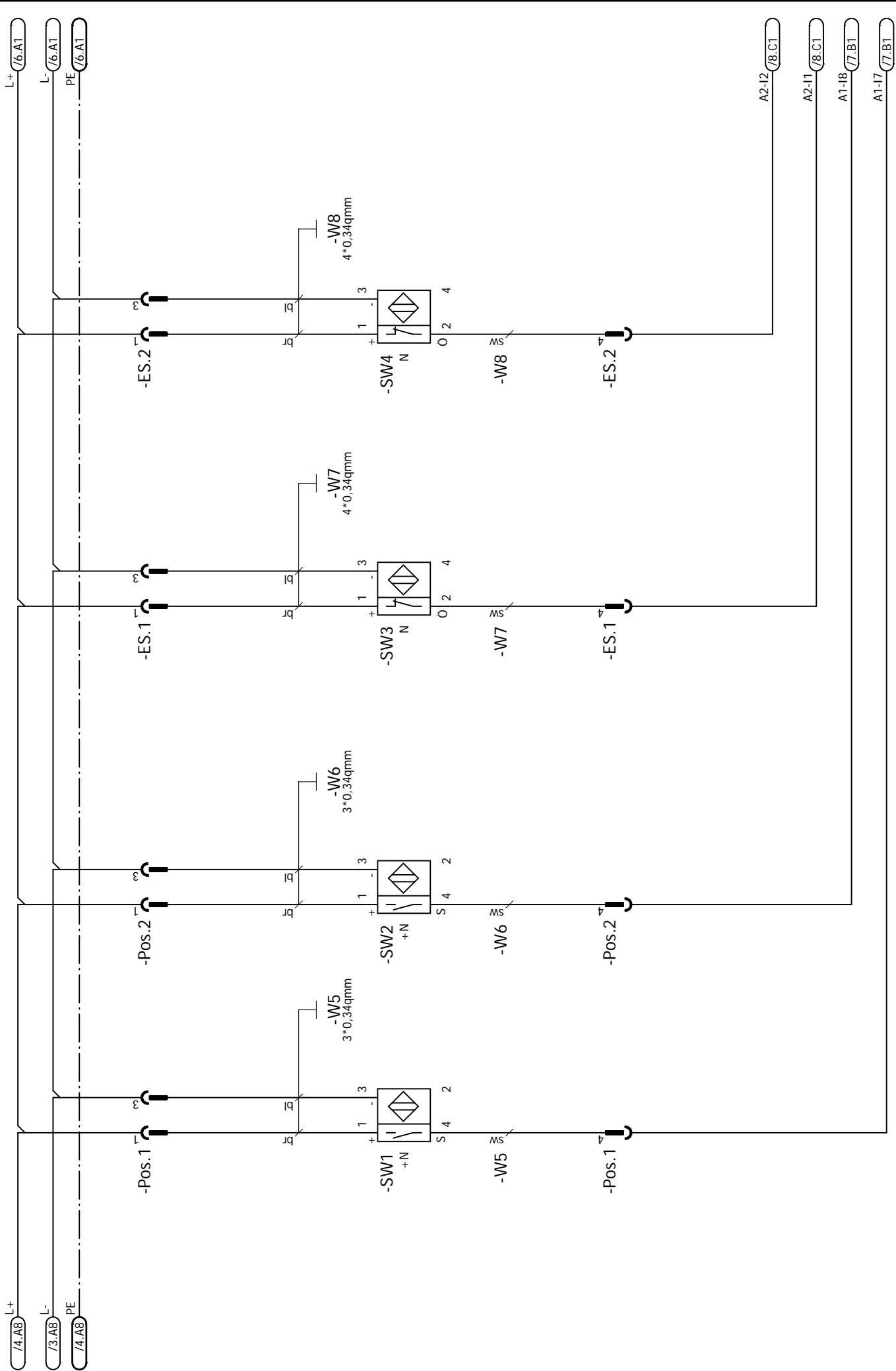

R. Änderung	Datum	Name	Ursprung	Ersatz für	Ersatz durch	Stromlaufplan 5	Initiatoren Haupthubwerk
	21.04.2008	Bearbeiter Schwarze				ML40/50 Serie	AB - Nr.: /
		Geprüft					Geräte-Nr.: ML_40_50
		Norm					Blatt 5 15 Bl.





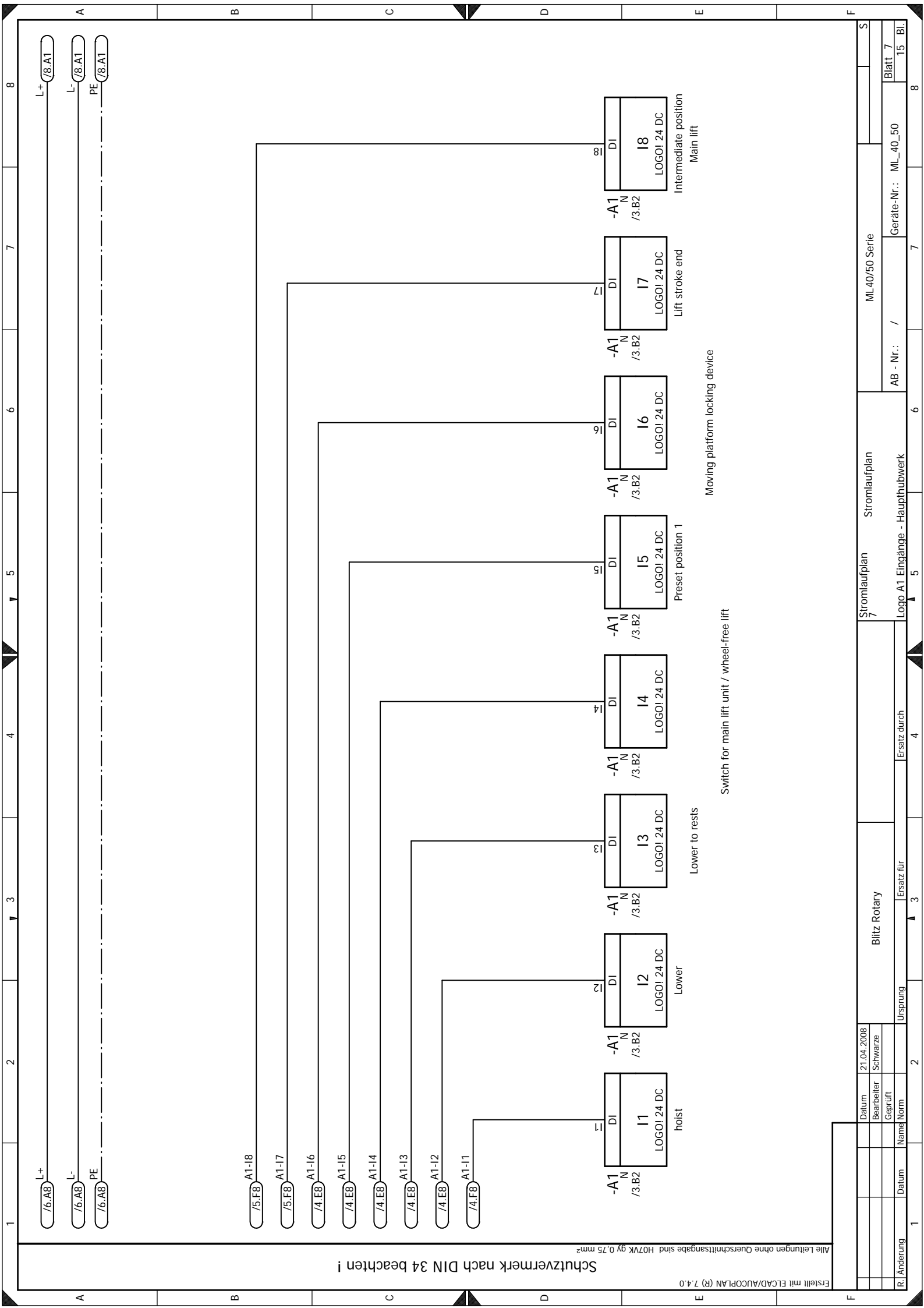



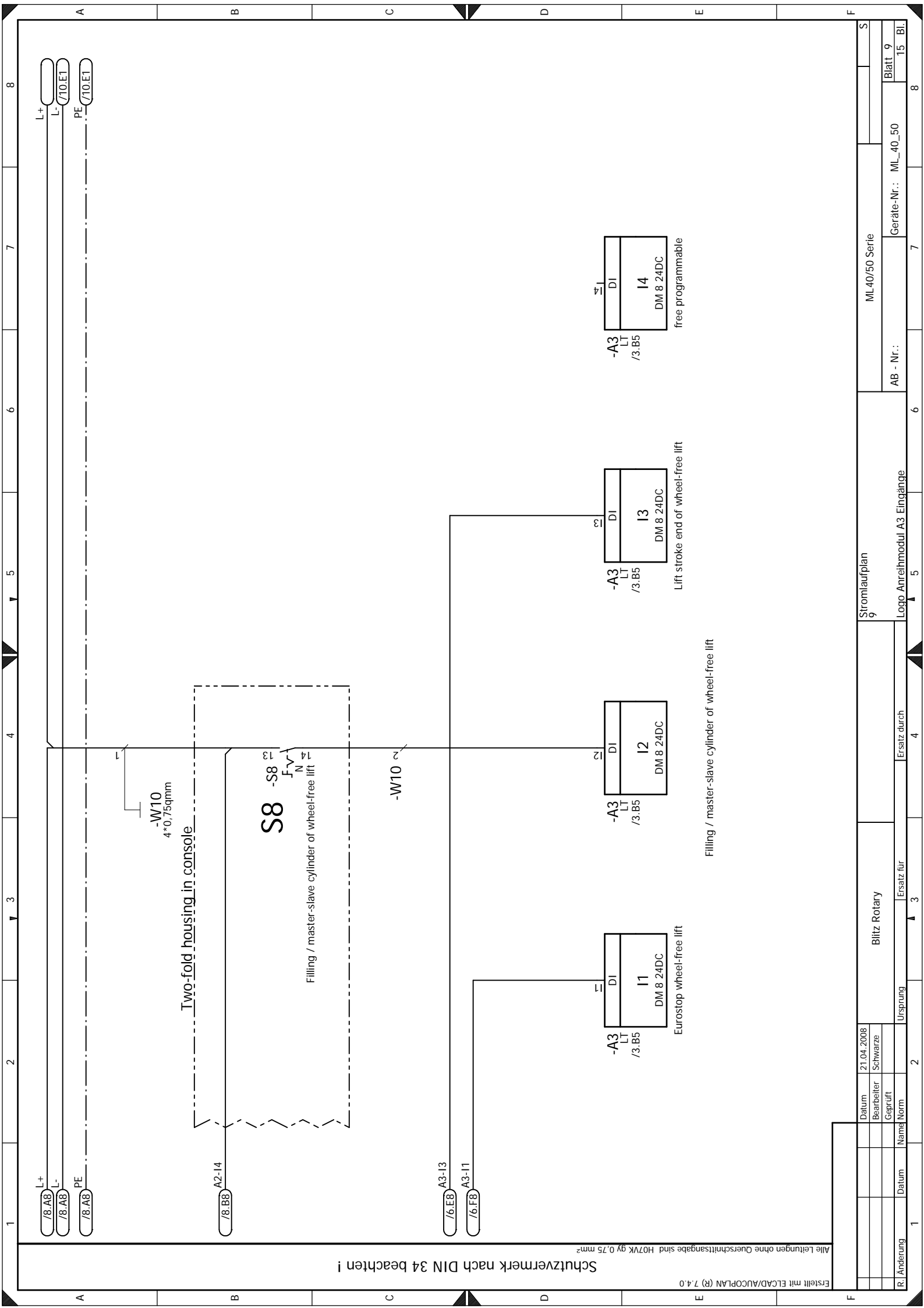

Schutzvermerk nach DIN 34 beachten !  
 Alle Leitungen ohne Querschnittsangaben sind H07VK gy 0,75 mm<sup>2</sup>

Erstellt mit ELCAD/AUCOPLAN (R) 7.4.0

R. Änderung	Datum	Name	Ursprung	Ersatz für	Ersatz durch	Logo Anreihmodul A3 Eingänge	AB - Nr.:	ML_40_50	Blatt	9	15	Bl.
	Datum	21.04.2008	Bearbeiter	Schwarze		Stromlaufplan		ML40/50 Serie				

Schutzvermerk nach DIN 34 beachten !  
 Alle Leitungen ohne Querschnittsangaben sind H07VK gy 0,75 mm<sup>2</sup>

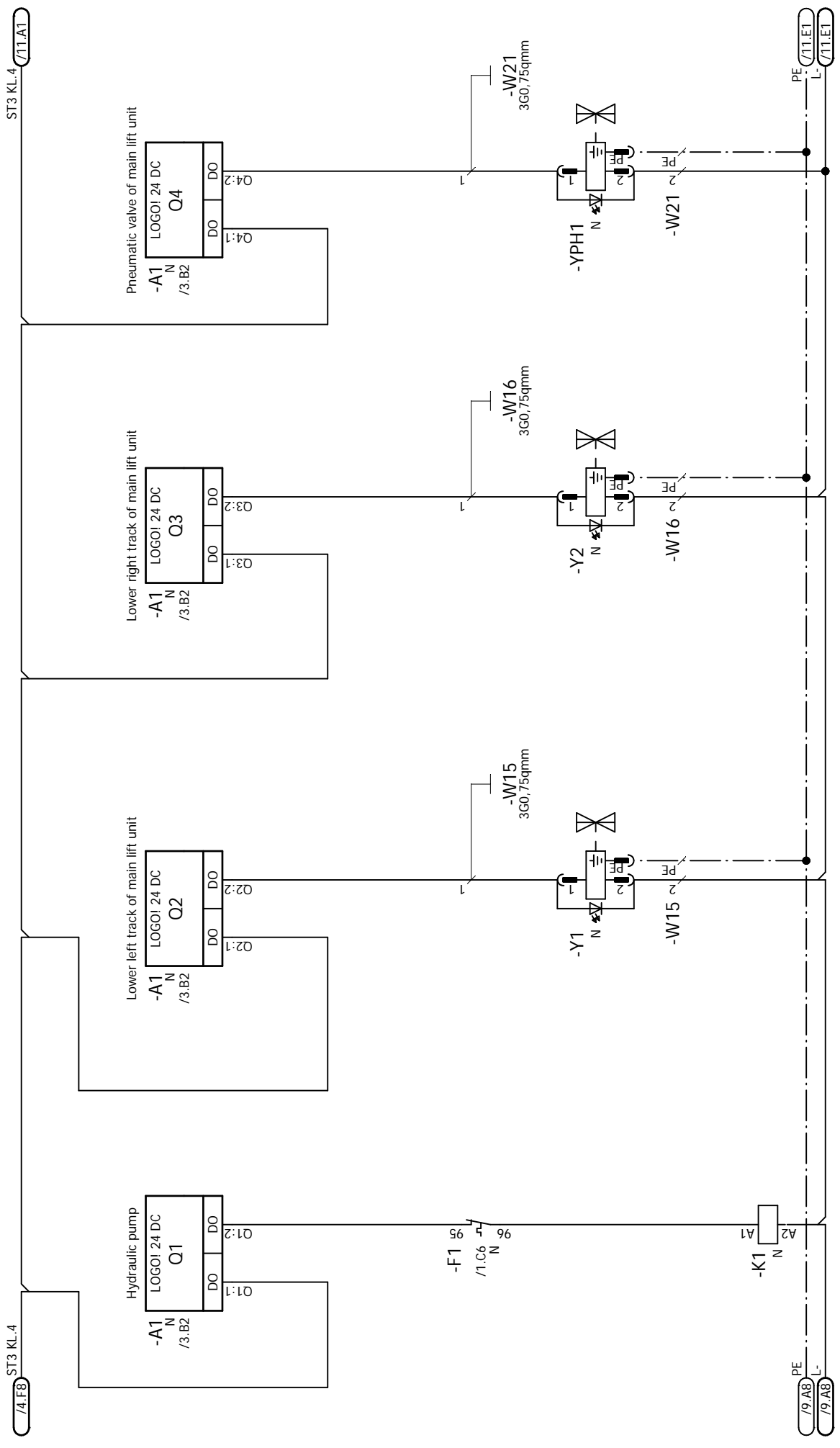

Motor contactor, hydraulic pump

- 1 /1.B6
- 2 /1.B6
- 3 /1.B6
- 4 /1.B6
- 5 /1.B6
- 6 /1.B6

R. Änderung	Datum	Name	Ursprung	Ersatz für	Ersatz durch	Blatt	Bl.
	21.04.2008	Blitz Rotary	Schwarze			10	10
						15	15
Geräte-Nr.:			ML_40_50				
AB - Nr.:			ML_40_50				
Stromlaufplan			ML40/50 Serie				

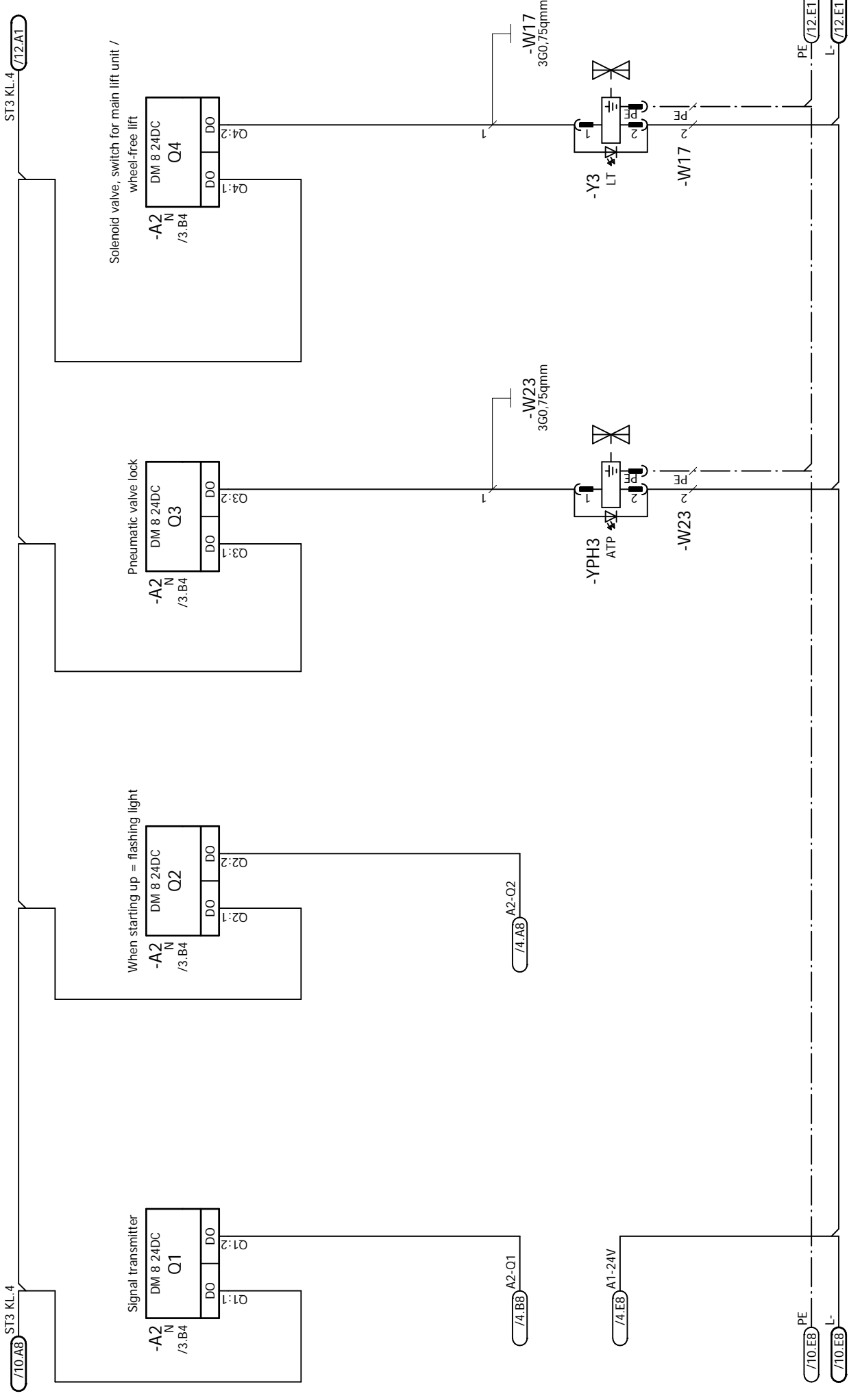

Schutzvermerk nach DIN 34 beachten !  
 Alle Leitungen ohne Querschnittsangaben sind H07VK gy 0,75 mm<sup>2</sup>

Erstellt mit ELCAD/AUCOPLAN (R) 7.4.0

R. Änderung		Datum	Name	Ursprung		Ersatz für		Ersatz durch		Logo A2 Ausgänge Zusatzhubwerk		AB - Nr.:	Geräte-Nr.:	ML40/50 Serie	Stromlaufplan		
1				2		3		4		5		ML_40_50	15	ML40/50 Serie	11		
Blitz Rotary		21.04.2008	Schwarze	Blitz Rotary		Blitz Rotary		Blitz Rotary		Blitz Rotary		Blitz Rotary		Blitz Rotary		Blitz Rotary	
2				3		4		5		6		7		8		9	
1				2		3		4		5		6		7		8	

Schutzvermerk nach DIN 34 beachten !

Erstellt mit ELCAD/AUCOPLAN (R) 7.4.0

Alle Leitungen ohne Querschnittsangaben sind H07VK gy 0,75 mm<sup>2</sup>

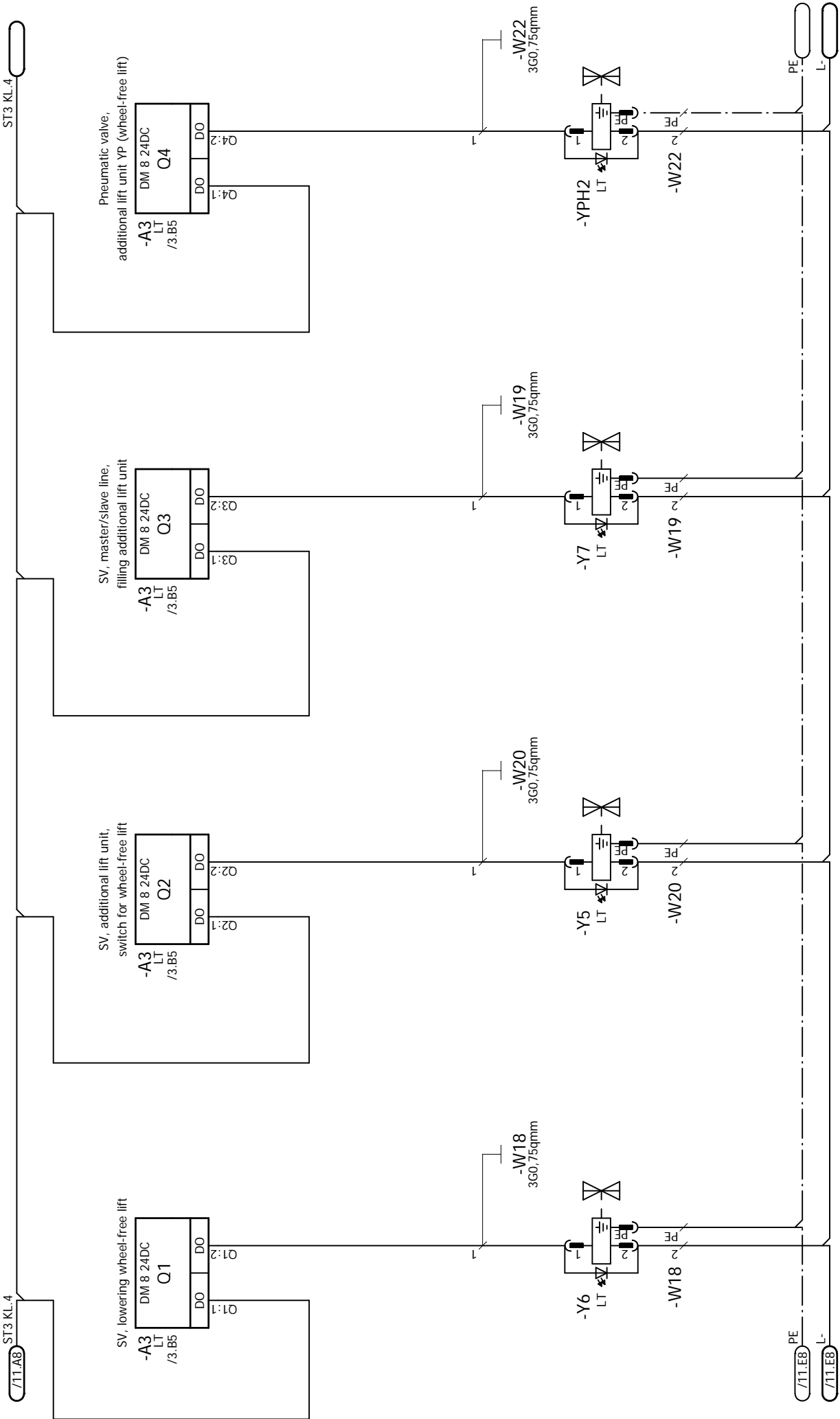

R. Änderung	Datum	Name	Ursprung	Ersatz für	Ersatz durch

Datum	21.04.2008
Bearbeiter	Schwarze
Geprüft	
Norm	

Blitz Rotary	
Ursprung	Ersatz für

Stromlaufplan 12	
Logo A3 Ausgänge Zusatzhub	

ML40/50 Serie	
AB - Nr.:	/
Geräte-Nr.:	ML_40_50
Blatt - 12	15
Blatt - 15	Bl.

Control line

12m pro Tisch

Helukabel Supertronic-PVC 10x0,25mm<sup>2</sup>

Art.Nr.: 49566

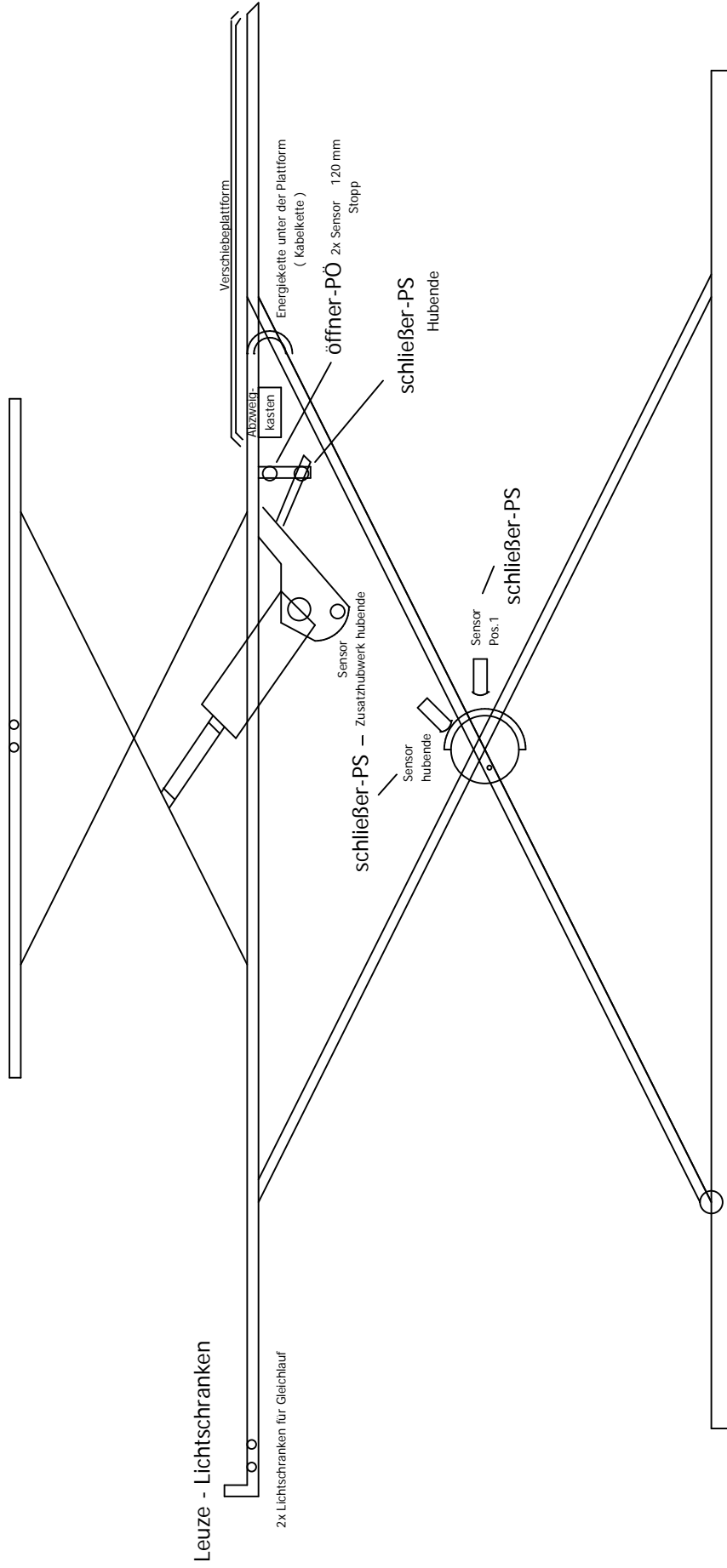

PO = öffner

PS = schließer

Haupthubwerk links  
außerhalb an der Schere  
Eurostopp 2 ( SW3 )

Haupthubwerk links  
innerhalb an der Schere  
Zwischenposition Pos.1 ( SW2 )

PO = öffner

PS = schließer

Haupthubwerk rechts  
außerhalb an der Schere  
Eurostopp 1 ( SW4 )

Haupthubwerk rechts  
innerhalb an der  
Schere = Hubende ( SW1 )

Schutzvermerk nach DIN 34 beachten !

Alle Leitungen ohne Querschnittsangaben sind H07VK gy 0,75 mm<sup>2</sup>

Erstellt mit ELCAD/AUCOPLAN (R) 7.4.0

R. Änderung	Datum	Name	Ursprung	Ersatz für	Ersatz durch

Datum	21.04.2008
Bearbeiter	Schwarze
Geprüft	
Norm	

Blitz Rotary	
Ursprung	Ersatz für

Stromlaufplan 13	
Sensor - Übersicht ML40	

Geräte-Nr.:	ML_40_50	Blatt	13
AB - Nr.:			15
			Bl.
			8



# Blitz Rotary Terminal

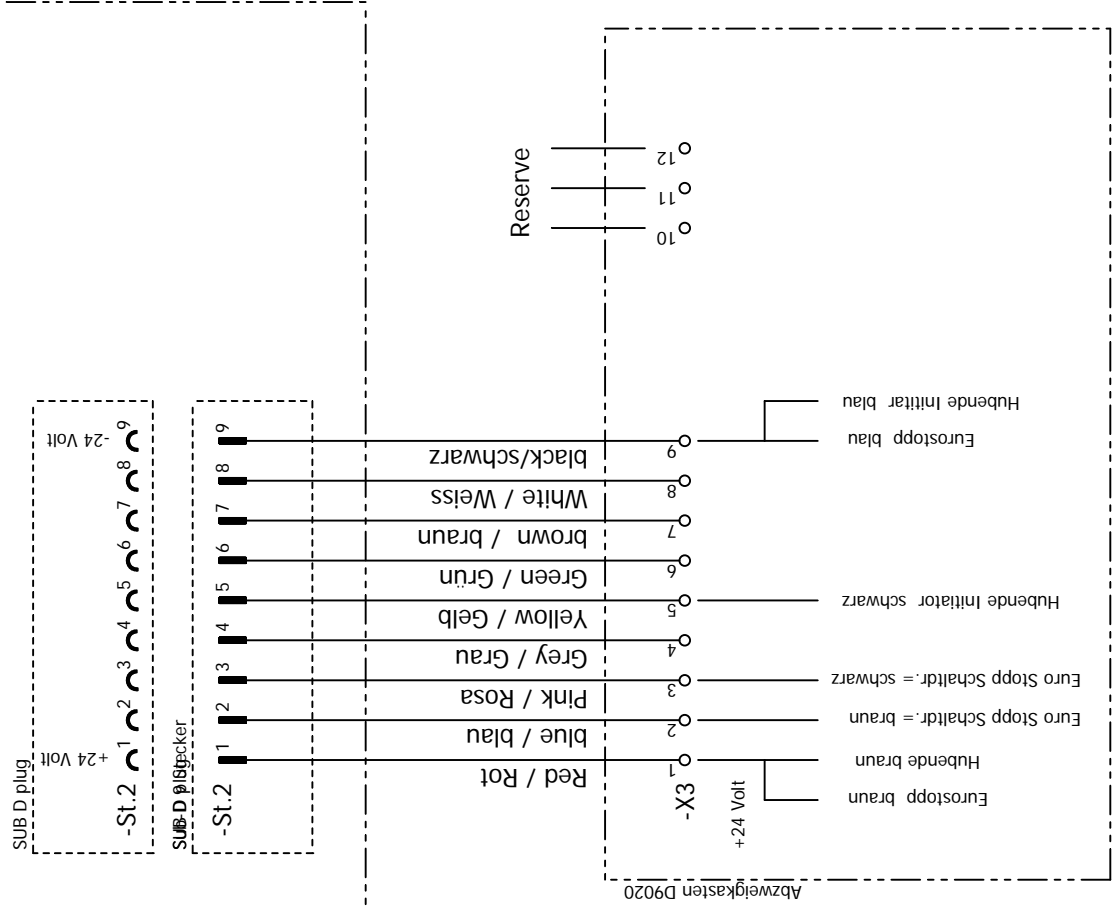

ein Initiator = öffener EDV-Nr.: 10.30.585 (Sick)  
 2 Lichtschranken Leuze = schließter EDV-Nr.: 10.30.584 (Leuze)

## Initiatoren Zusatzhubwerk (RFH) linke Bahn

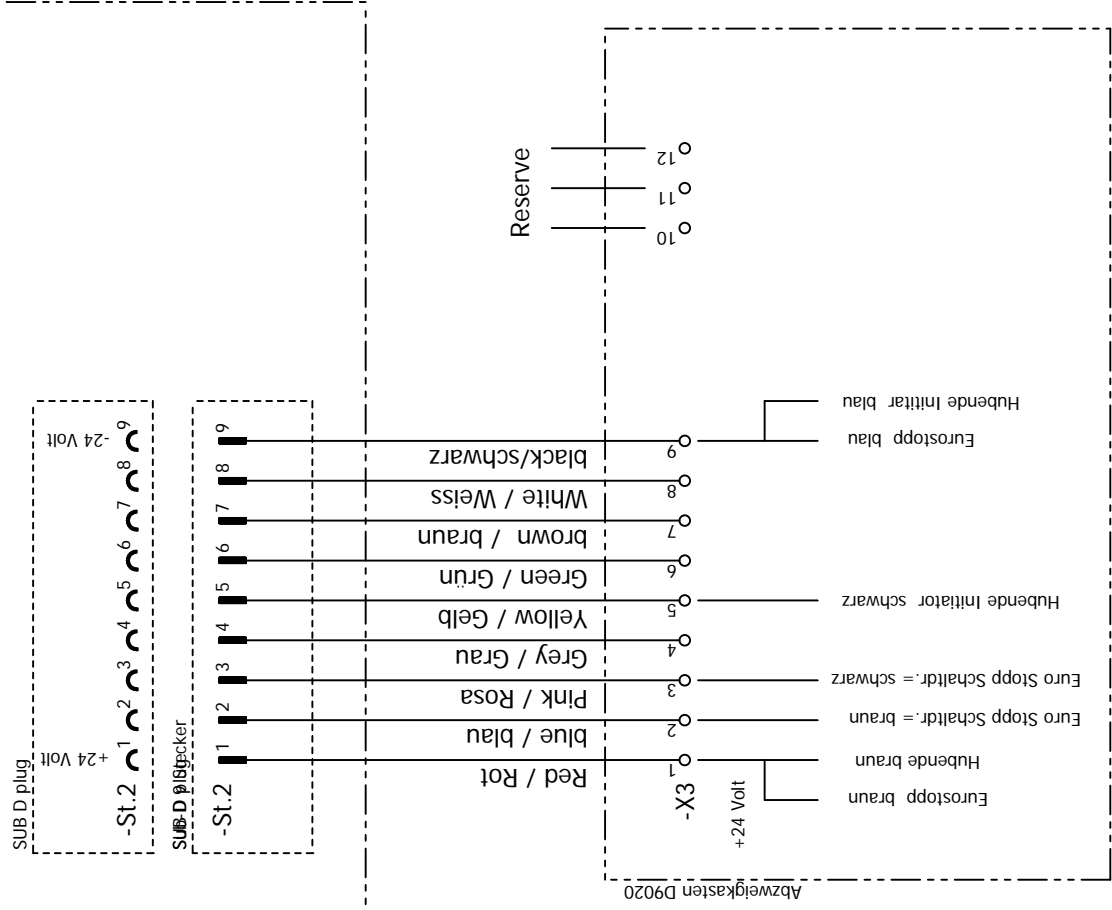

ein Initiator = schließter EDV-Nr.: 10.30.575 für Hubende (Sick)  
 ein Initiator = öffener EDV-Nr.: 10.30.585 für Eurostopp (Sick)  
 Lichtschranken Reflektoren = (Spiegel) EDV-Nr.: 10.30.509 (Bernstein)

## Initiatoren Zusatzhubwerk (RFH) rechte Bahn

Schutzvermerk nach DIN 34 beachten!

Erstellt mit ELCAD/AUCOPLAN (R) 7.4.0

R. Änderung	Datum	Name	Ursprung	Ersatz für	Ersatz durch	Zusatzhubwerk Radfreiheber	AB - Nr.:	Geräte-Nr.:	ML_40_50	Blatt	14	15	Bl.
Datum				21.04.2008		Blitz Rotary		ML40/50 Serie					
Bearbeiter				Schwarze									
Geprüft													
Norm													
Stromlaufplan				14									

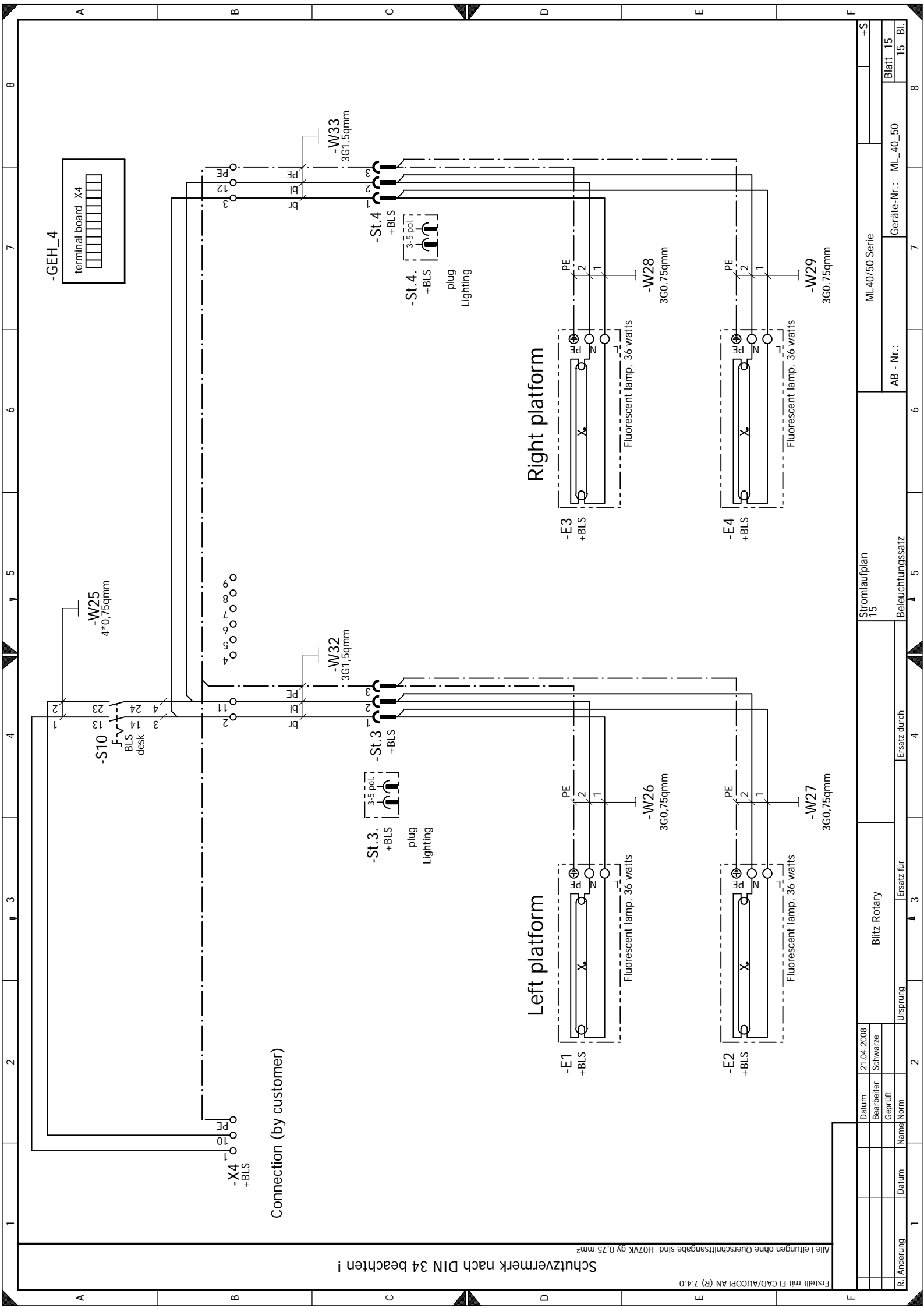

Schutzvermerk nach DIN 34 beachten !

Alle Leitungen ohne Querschnittsangaben sind H07VK gy 0,75 mm²

Erstellt mit ELCAD/AUCOPLAN (R) 7.4.0

R. Änderung	Datum	Name

Datum	21.04.2008
Bearbeiter	Schwarze
Geprüft	
Norm	

Ursprung	Ersatz für
Blitz Rotary	Ersatz durch

Stromlaufplan	15
Beleuchtungssatz	

AB - Nr.:	
Geräte-Nr.:	ML_40_50
Blatt	15
Bl.	15

Connection (by customer)

Left platform

Right platform

-GEH\_4

terminal board X4

-W25  
4\*0,75qmm

-S10  
FV  
BLS  
desk

-W33  
3G0,75qmm

-W32  
3G0,75qmm

-W28  
3G0,75qmm

-W26  
3G0,75qmm

-W29  
3G0,75qmm

-W27  
3G0,75qmm

-St.4  
+BLS

-St.3  
+BLS

plug  
Lighting

plug  
Lighting

-E3  
+BLS

-E1  
+BLS

-E4  
+BLS

-E2  
+BLS

Fluorescent lamp, 36 watts

Fluorescent lamp, 36 watts

Fluorescent lamp, 36 watts

Fluorescent lamp, 36 watts

1 2 3 4 5 6 7 8

A B C D E F















Schutzvermerk nach DIN 34 beachten !

R. Änderung	Datum	Name	Norm	Geprüft	Schwarze	Datum	06.06.2008	Blitz Rotary	Ersatz für	Ersatz durch	Klemmenplan			Geräte-Nr.:	ML_40_50	Blatt 7		
											7		+S				ML_40_50	11
											+S-Pos.2							
Klemme												Anzahl freier Adern		Kabel intern				
Typ : 1,3,4												Anzahl freier Adern		Kabel intern				
3x0,34mm²												Anzahl freier Adern		Kabel intern				
W6												Anzahl freier Adern		Kabel intern				
0												Anzahl freier Adern		Kabel intern				
Zielzeichen extern												Zielzeichen intern		Gerätekommentar				
Anlage	Einbauort	Gerät	Anschluß	Anlage		Einbauort	Gerät	Anschluß	Anlage		Einbauort	Gerät	Anschluß	Anlage		Einbauort	Gerät	Anschluß
	+N	-SW2	+															
	+N	-SW2	-															
	+N	-SW2	S															
Zielzeichen intern												Zielzeichen intern		Gerätekommentar				
Leiste : -Pos.2												Zielzeichen intern		Gerätekommentar				
Klemmenanzahl : 3												Zielzeichen intern		Gerätekommentar				
1												Zielzeichen intern		Gerätekommentar				
/5.A4												Zielzeichen intern		Gerätekommentar				
3												Zielzeichen intern		Gerätekommentar				
/5.A4												Zielzeichen intern		Gerätekommentar				
4												Zielzeichen intern		Gerätekommentar				
/5.D4												Zielzeichen intern		Gerätekommentar				
Logo mini controller												Zielzeichen intern		Gerätekommentar				
PE-PEN-Schiene												Zielzeichen intern		Gerätekommentar				
N-Schiene												Zielzeichen intern		Gerätekommentar				

Schutzvermerk nach DIN 34 beachten !

Anz. freier Adern	Klemme		Anschluß	Zielzeichen extern				Zielzeichen intern				Anz. freier Adern			
	Typ	Klemme		Anlage	Einbauort	Gerät	Anschluß	Anlage	Einbauort	Gerät	Anschluß				
													Typ		Zielzeichen intern
	0	H07VK gy 0,75 mm <sup>2</sup>													
	6	W30 10x0,25mm <sup>2</sup>													

Anschlußleiste				Allgemeine Hinweise	
Klempennummer	Typ	Laschverbindungen	Kommentar	Darstellung	Anz. freier Adern

Klempennummer	Typ	Laschverbindungen	Kommentar	Darstellung	Zielzeichen extern				Zielzeichen intern				Anz. freier Adern		
					Anlage	Einbauort	Gerät	Anschluß	Anlage	Einbauort	Gerät	Anschluß			

Blitz Rotary		Blitz Rotary		Blitz Rotary	
Datum	06.06.2008	Datum	06.06.2008	Datum	06.06.2008
Bearbeiter	Schwarze	Bearbeiter	Schwarze	Bearbeiter	Schwarze
Geprüft		Geprüft		Geprüft	
Norm		Norm		Norm	
Name		Name		Name	
Datum		Datum		Datum	
Ursprung		Ersatz für		Ersatz durch	
Klemmenplan		Klemmenplan		Klemmenplan	
8		8		8	
+S		+S		+S	
Geräte-Nr.: ML_40_50		Geräte-Nr.: ML_40_50		Geräte-Nr.: ML_40_50	
AB - Nr.: /		AB - Nr.: /		AB - Nr.: /	
Blatt 8		Blatt 8		Blatt 8	
11		11		11	
BI.		BI.		BI.	







# Geräte-Stückliste

Nr.	Betriebsmittel Kommentar	Artikelnummer Zusatzinfo 1 Zusatzinfo 2	Bezeichnung 1 + 2	Hersteller	Art Typ
1	<b>+ATP-S7</b> Darstellung /A,C6	10.30.587	Knebeschalter	TAIWAN	S
2	<b>+ATP-YPH3</b> /11.D6	10.30.048	Magnetspule 24VDC	GR.08.24	Y
3	<b>+ATP-YPH3</b> /11.D6	10.30.818	MV-Stecker Pneumatik 11mm	MURRELEKTRONIK	W
4	<b>+BLS-E1</b> Fluorescent lamp, 36 watts /15.D3	10.30.815 230V / 50Hz / 36W	Leuchstoffleuchte	TECHMALUX	E
5	<b>+BLS-E1</b> Fluorescent lamp, 36 watts /15.D3	10.30.816	Befestigungssatz für Leuchstoffleuchte	TECHMALUX	E
6	<b>+BLS-E2</b> Fluorescent lamp, 36 watts /15.E3	10.30.815 230V / 50Hz / 36W	Leuchstoffleuchte	TECHMALUX	E
7	<b>+BLS-E2</b> Fluorescent lamp, 36 watts /15.E3	10.30.816	Befestigungssatz für Leuchstoffleuchte	TECHMALUX	E
8	<b>+BLS-E3</b> Fluorescent lamp, 36 watts /15.D7	10.30.815 230V / 50Hz / 36W	Leuchstoffleuchte	TECHMALUX	E
9	<b>+BLS-E3</b> Fluorescent lamp, 36 watts /15.D7	10.30.816	Befestigungssatz für Leuchstoffleuchte	TECHMALUX	E
10	<b>+BLS-E4</b> Fluorescent lamp, 36 watts /15.E7	10.30.815 230V / 50Hz / 36W	Leuchstoffleuchte	TECHMALUX	E
11	<b>+BLS-E4</b> Fluorescent lamp, 36 watts /15.E7	10.30.816	Befestigungssatz für Leuchstoffleuchte	TECHMALUX	E
12	<b>+BLS-GEH 4</b> terminal board X4 /15.A7	10.30.677	Abzweigdose	HENSEL	G
13	<b>+BLS-S10</b> desk /15.A4	10.30.418	Taster	D 9020	S
14	<b>+BLS-S10</b> desk /15.A4	10.30.456	Hilfsschalterblock Frontbefestigung Schl	ZBS-AA0	S
15	<b>+BLS-S10</b> desk /15.A4	10.30.410	Tastergehäuse 1fach	TELEMECANIQUE NEU	S
16	<b>+BLS-S1.3</b> plug Lighting /15.C4	10.30.681	Kupplungsgehäuse	XAL-K01	X
17	<b>+BLS-S1.3</b> plug Lighting /15.C4	10.30.682	Tüllengehäuse	WALTER .703803	X
18	<b>+BLS-S1.3</b> plug Lighting /15.C4	10.30.683	Stiftensatz 5pol.	WALTER .702803	X
19	<b>+BLS-S1.3</b> plug Lighting /15.C4	10.30.684	Buchseinsatz 5pol.	WALTER .700204	X
20	<b>+BLS-S1.4</b> plug Lighting /15.C7	10.30.681	Kupplungsgehäuse	WALTER .700104	X

Bemerkungen :

R. Änderung		Datum	Name	Ursprung	Ersatz für	Stücklisten	AB - Nr.:	Geräte-Nr.:	Blatt 1
		08.05.2008	Bearbeiter Schwarze			1	ML_40_50		5 Bl.

# Geräte-Stückliste

Nr.	Betriebsmittel Kommentar	Artikelnummer	Bezeichnung 1 + 2	Art
	Darstellung	Zusatzinfo 1	Bestellnummer	Typ
21	<b>+BLS-St.4.</b> plug Lighting /15.C7	10.30.682	Tüllengehäuse WALTER	X
22	<b>+BLS-St.4.</b> plug Lighting /15.C7	10.30.683	Stiftensatz 5pol. WALTER	X
23	<b>+BLS-St.4.</b> plug Lighting /15.C7	10.30.684	Buchseinsatz 5pol. WALTER	X
24	<b>+LT-A3</b> Logo add-on module /3.B5	10.30.239	LOGO! Anreihmodul DM8 12/24VDC SIEMENS	A
25	<b>+LT-S5</b> /4.C5	10.30.587	6ED1 055-1MB00-0BA1 Knebschalter TAIWAN	S
26	<b>+LT-SW5</b> Lift stroke end of wheel-free lift /6.C7	10.30.575	Indukt. Näherungsschalt. IME12-04NPSZU6S SICK	B
27	<b>+LT-SW8</b> Eurostop wheel-free lift /6.B5	10.30.585	Induktiver Näherungsschalter M12 Öffner SICK	B
28	<b>+LT-SW8/1</b> Eurostop wheel-free lift /6.D5	10.30.585	Induktiver Näherungsschalter M12 Öffner SICK	B
29	<b>+LT-Y3</b> /11.D8	10.30.048	Magnetspule 24VDC R	Y
30	<b>+LT-Y3</b> /11.D8	10.30.392	GR 08.24 MV-Leitung MSUD 24V AC/DC 5m MURRELEKTRONIK	W
31	<b>+LT-Y5</b> /12.D4	10.30.048	7000-18021-2160500 Magnetspule 24VDC R	Y
32	<b>+LT-Y5</b> /12.D4	10.30.392	GR 08.24 MV-Leitung MSUD 24V AC/DC 5m MURRELEKTRONIK	W
33	<b>+LT-Y6</b> /12.D2	10.30.048	7000-18021-2160500 Magnetspule 24VDC R	Y
34	<b>+LT-Y6</b> /12.D2	10.30.392	GR 08.24 MV-Leitung MSUD 24V AC/DC 5m MURRELEKTRONIK	W
35	<b>+LT-Y7</b> /12.D6	10.30.048	7000-18021-2160500 Magnetspule 24VDC R	Y
36	<b>+LT-Y7</b> /12.D6	10.30.392	GR 08.24 MV-Leitung MSUD 24V AC/DC 5m MURRELEKTRONIK	W
37	<b>+LT-YPH2</b> /12.D8	10.30.048	7000-18021-2160500 Magnetspule 24VDC R	Y
38	<b>+LT-YPH2</b> /12.D8	10.30.818	GR 08.24 MV-Stecker Pneumatik 11mm MURRELEKTRONIK	W
39	<b>+N-A1</b> Logo mini controller /3.B2	10.30.237	7000-11081-236-0150 LOGO! Kleinsteuerung 12/24VDC SIEMENS	A
40	<b>+N-A2</b> Logo add-on module /3.B4	10.30.239	6ED1 052-1MD00-0BA4 LOGO! Anreihmodul DM8 12/24VDC SIEMENS	A

Bemerkungen :

R. Änderung	Datum	Name	Geprüft	Norm
	08.05.2008		Schwarze	
Blitz Rotary				
Ursprung			Ersatz für	
Stücklisten			2	
AB - Nr.:			ML_40_50	
Geräte-Nr.:			ML_40_50	
			Blatt 2	
			5 Bl.	

Schutzvermerk nach DIN 34 beachten !

# Geräte-Stückliste

Nr.	Betriebsmittel Kommentar	Artikelnummer Zusatzinfo 1 Zusatzinfo 2	Bezeichnung 1 + 2 Hersteller Bestellnummer Typ	Art Typ
41	<b>+N-BYPT1</b> Sound transducer /4.C8	10.30.289	Schallwandler	H
42	<b>+N-F1</b> Bimetal /1.C6	10.30.660	Bimetallrel.7-10A SIEMENS	F
43	<b>+N-G1</b> supply unit 5A /2.C3	10.30.817	3RU1116-1JB0 24V DC supply BLOCK ***	G
44	<b>+N-GEHL_1</b> desk /1.D3			G
45	<b>+N-GEHL_2</b> terminal board X2	10.30.677	Abzweigdose HENSEL D 9020	G
46	<b>+N-GEHL_3</b> terminal board X3	10.30.677	Abzweigdose HENSEL D 9020	G
47	<b>+N-H1</b> In operation = continuous light /4.C7	10.30.576	Leuchtmelder TAIWAN	H
48	<b>+N-K1</b> Motor contactor, hydraulic pump /10.E2	10.30.652	Schutz 24VDC SIEMENS 3RT1017-1BB42	K
49	<b>+N-S2</b> hoist /4.C3	10.30.572	Taster heben TAIWAN	S
50	<b>+N-S3</b> Lower /4.C3	10.30.573	Taster Senken TAIWAN	S
51	<b>+N-S4</b> Lower to rests /4.D3	10.30.573	Taster Senken TAIWAN	S
52	<b>+N-S6</b> /4.C5	10.30.586	Taster schwarz Fronteinbau TAIWAN	S
53	<b>+N-S8</b> Filling / master-slave cylinder of wheel-free lift /9.B4	10.30.427	Drehsch.Li.-Rast TELEMECANIQUE NEU	S
54	<b>+N-S8</b> Filling / master-slave cylinder of wheel-free lift /9.B4	10.30.454	ZBS-AD2 Hilfsschalterblock Bodenbefestigung Schl TELEMECANIQUE NEU	S
55	<b>+N-S8</b> Filling / master-slave cylinder of wheel-free lift /9.B4	10.30.412	ZEN-L111 Tastergehäuse 2fach TELEMECANIQUE NEU	S
56	<b>+N-S9</b> Bypass for synchronisation monitor /8.B7	10.30.427	XAL-D02 Drehsch.Li.Re.-Rast TELEMECANIQUE NEU	S
57	<b>+N-S9</b> Bypass for synchronisation monitor /8.B7	10.30.454	ZBS-AD2 Hilfsschalterblock Bodenbefestigung Schl TELEMECANIQUE NEU	S
58	<b>+N-S01</b> main switch /1.C2	10.30.574	ZEN-L111 Hauptschalter TAIWAN	S
59	<b>+N-SW1</b> /5.C2	10.30.575	Indukt. Näherungsschalt. IME12-04NPSZU6S SICK	B
60	<b>+N-SW1</b> /5.C2	10.30.820	Rundsteckverbinder MT12 1,5m MURRELEKTRONIK	W

Bemerkungen :

R. Änderung	Datum	Name	Ursprung
	08.05.2008	Bearbeiter Schwarze	Ersatz für
			Blitz Rotary
			Stücklisten
			3
			AB - Nr.:
			Geräte-Nr.:
			ML_40_50
			Blatt 3
			5 Bl.



# Geräte-Stückliste

Nr.	Betriebsmittel		Artikelnummer	Bezeichnung 1 + 2		Art
	Kommentar	Zusatzinfo 1		Hersteller	Typ	
61	+N-SW1		10.30.747	Rundsteckverbinder M12 4pol. Stift gerade	X	27605
62	+N-SW2	/5.C2	10.30.575	Indukt. Näherungsschalt. IME12-04NPSZU6S	B	
63	+N-SW2	/5.C4	10.30.820	Rundsteckverbinder M12 1.5m	W	
64	+N-SW2	/5.C4	10.30.747	Rundsteckverbinder M12 4pol. Stift gerade	X	27605
65	+N-SW3	/5.C4	10.30.585	Induktiver Näherungsschalter M12 Öffner	B	
66	+N-SW3	/5.C5	10.30.820	Rundsteckverbinder M12 1.5m	W	
67	+N-SW3	/5.C5	10.30.747	Rundsteckverbinder M12 4pol. Stift gerade	X	27605
68	+N-SW4	/5.C7	10.30.585	Induktiver Näherungsschalter M12 Öffner	B	
69	+N-SW4	/5.C7	10.30.820	Rundsteckverbinder M12 1.5m	W	
70	+N-SW4	/5.C7	10.30.747	Rundsteckverbinder M12 4pol. Stift gerade	X	27605
71	+N-SW9	/6.B2	10.30.584	Reflexionslichtschranke max. 6m M18	B	
72	+N-SW9	/6.B2	10.30.819	Reflektor 50*120mm	H	
73	+N-SW9	/6.B2	10.30.297	Sensorleitung M12 mit LED 10m	W	
74	+N-SW9/1	/6.D2	10.30.584	Reflexionslichtschranke max. 6m M18	B	
75	+N-SW9/1	/6.D2	10.30.297	Sensorleitung M12 mit LED 10m	W	
76	+N-SI.1	/6.A4	St.1	Sub-D9 Stecker	X	Sub-D9
77	+N-SI.1	/6.A4	58.50.026	Steuerleitung Initiatoren Radfreibeher	W	
78	+N-SI.2	/6.A4	St.2	Sub-D9 Stecker	X	Sub-D9
79	+N-SI.2	/6.D4	58.50.026	Steuerleitung Initiatoren Radfreibeher	W	
80	+N-Y1	/6.D4	10.30.048	Magnetspule 24VDC	Y	
			/10.D4	GR.08.24		

Bemerkungen :

R. Änderung	Datum	Name	Geprüft	Norm	Ursprung	Ersatz für	Ersatz durch
	08.05.2008		Schwarze			Blitz Rotary	Stücklisten
						4	4
							AB - Nr.:
							Geräte-Nr.:
							ML_40_50
							Blatt 4
							5 Bl.

# Geräte-Stückliste

Nr.	Betriebsmittel Kommentar	Artikelnummer	Bezeichnung 1 + 2		Art
			Hersteller	Typ	
81	+N-Y1	Zusatzinfo 1 Darstellung 10.30.392	MV-Leitung MSUD 24V AC/DC 5m MURRELEKTRONIK	W	
	/10.D4		7000-18021-2160500		
82	+N-Y2	10.30.048	Magnetspule 24VDC	Y	
	/10.D6		GR.08.24		
83	+N-Y2	10.30.392	MV-Leitung MSUD 24V AC/DC 5m MURRELEKTRONIK	W	
	/10.D6		7000-18021-2160500		
84	+N-YPH1	10.30.048	Magnetspule 24VDC	Y	
	/10.D7		GR.08.24		
85	+N-YPH1	10.30.818	MV-Stecker Pneumatik 11mm MURRELEKTRONIK	W	
	/10.D7		7000-11081-236-0150		
86	+N ML40-M1	Für Ausführung ML40 4000 KG	Hydraulikaggregat 3,6 KW	M	
	/1.D6				
87	+N ML50-M.1	Für Ausführung ML50 5000 KG	Hydraulikaggregat 4,0 KW	M	
	/1.D7				

Schutzvermerk nach DIN 34 beachten !

Bemerkungen :

R. Änderung	Datum	Name	Ursprung	Ersatz für	Ersatz durch
	08.05.2008	Bearbeiter Schwarze Geprüft	Blitz Rotary		Blitz Rotary
Stücklisten				5	
AB - Nr.:				ML_40_50	Blatt 5
				5	Bl. 5

Trained Operators and Regular Maintenance Ensures  
Satisfactory Performance of Your Rotary Lift.

**Replacement Parts:** See installers package for parts breakdown sheet.  
Order Genuine Rotary replacement parts from your nearest Authorized Parts Distributor.

**Maintenance Assistance:** Contact your local Rotary distributor.

Should further assistance be required, contact Rotary Lift, at one of the phone numbers listed below.

World Headquarters:  
**Rotary Lift**  
A  **DOVER** COMPANY  
2700 Lanier Drive  
Madison, Indiana USA  
Phone: 1.800.445.5438  
Phone: 1.812.273.1622  
Fax: 1.800.578.5438  
Fax: 1.812.273.6502  
userlink@rotarylif.com  
www.rotarylif.com

Germany:  
(European Headquarters)  
**BlitzRotary GmbH**  
Bräunlingen  
Phone: +49.0771.9233.0  
Fax: +49.0771.9233.99  
europe@rotarylif.com

Canada:  
(Regional Sales Office)  
**Rotary Lift Canada**  
Mississauga, Ontario  
Phone: 888.256.4195  
Phone: 905.812.9920  
Fax: 905.812.9719  
canada@rotarylif.com

United Kingdom:  
(Regional Sales Office)  
**Rotary Lift (UK) LTD.**  
Halstead, Essex  
Phone: +44.178.747.7711  
Fax: +44.178.747.7720  
sales@rotarylif.idps.co.uk

Austral-Asia:  
(Regional Sales Office)  
**Rotary Lift Austral/Asia**  
Petaling Jaya, Malaysia  
Phone: +60.3.7660.0285  
Fax: +60.3.7660.0289  
rlim@rotarylif.com

